



ULTRACARE

At the Cutting Edge of Industry

EKA

SINGLE END TENONER

INSTRUCTION MANUAL No.847

Wadkin

SINGLE END TENONER, TYPE E. K. A.

PRINCIPAL DIMENSIONS AND CAPACITIES.

	English	Metric
Length of table	3'6"	1067mm
Width of table	2'2½"	673mm
Height of table	2'9"	838mm
Diameter of cutting-off saw ..	14"	356mm
Maximum diameter of cross cut saw for fixing to top tenon head.	14"	356mm
Diameter of grooving heads ..	11"	279mm
Maximum width of grooving heads	4"	102mm
Will admit timber up to	24" x 6"	610mm x 152mm
Will cut tenons at one operation	6" in length	152mm
Will trench or groove up to ..	24" wide	610mm
Will cross cut up to	24" wide	610mm
Will admit between table and cramps	7" deep	178mm
Will take 7'4" (2235mm) between shoulder of tenons using turn-over stop on table		
Fence may be swivelled 45° for angular tenoning		
Top cutterhead will raise 6½" (165mm) above the table		
Motors on all heads are 2 h. p. at 3,000 r. p. m. for 50 cycles and 3,600 r. p. m. for 60 cycles		
Floor space	7'9" x 8'3"	2362mm x 2515mm
Net weight with bottom scribing heads (in cwts)	27½ (3080lbs)	1397 kilos
Net weight with top and bottom scribing heads and cutoff saw (in cwts)	31½ (3528lbs)	1600 kilos
Shipping dimensions in cubic feet	200	3.66 cu. metres

DETAILS INCLUDED WITH THE MACHINE

Two tenon head motors and control gear
 Tenon cutterblocks with cutters
 Two guards

Set of spanners
 Lubricating pump and tin of lubricant

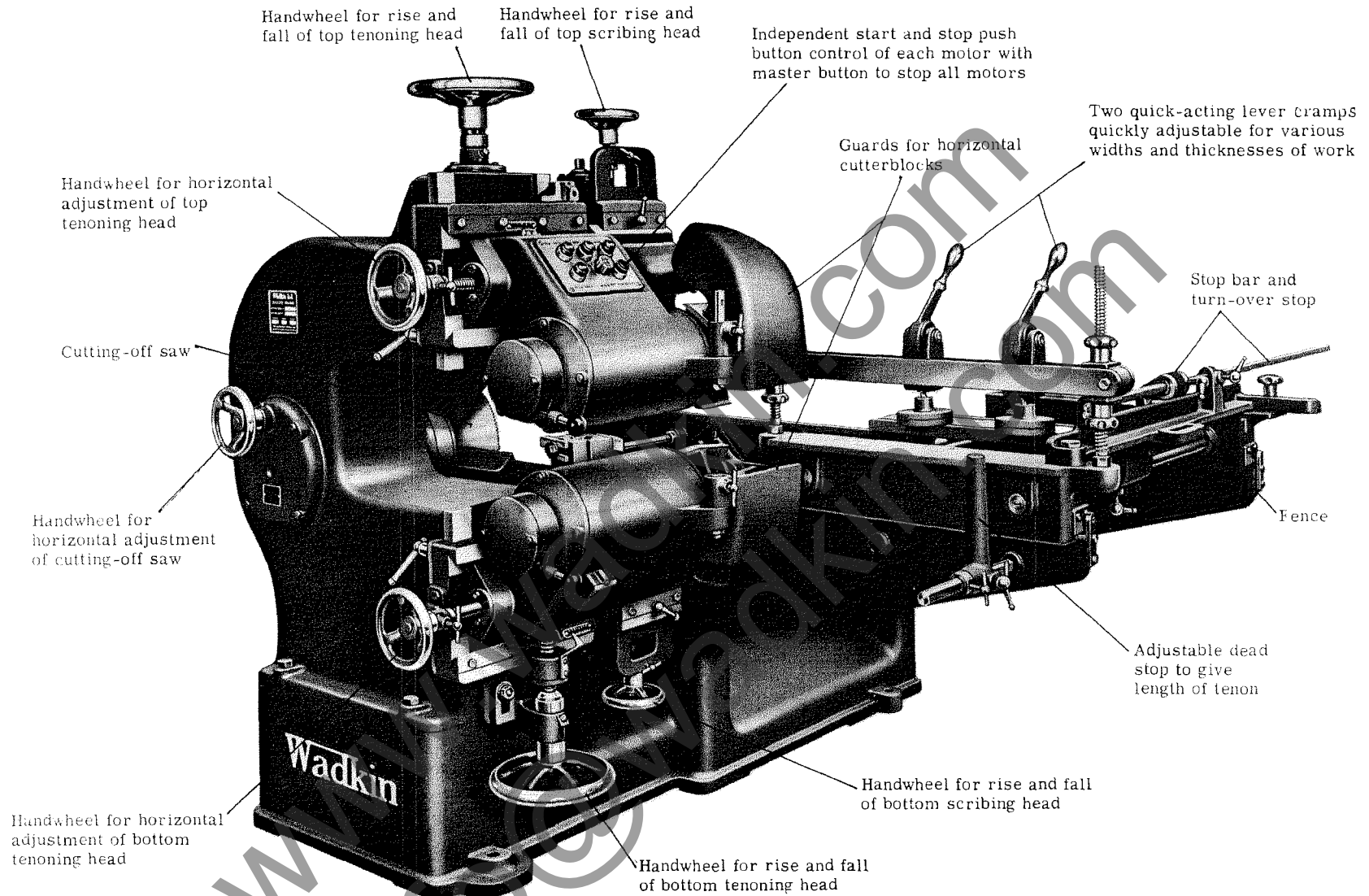

FIG. 1. GENERAL VIEW OF SINGLE END TENONER TYPE E. K. A.

INSTALLATION

The machine is despatched from the Works with all bright surfaces greased to prevent rusting. This protective covering should be removed by applying a cloth damped in paraffin or turpentine.

FOUNDATIONS.

Rag bolts $\frac{5}{8}$ " (16mm) diameter should be used to fix the machine to the floor, but these are not supplied by Wadkin Ltd. unless specially ordered. If the mill floor consists of 4" (100mm) to 6" (150mm) solid concrete no special foundation is necessary. The outline in Fig. 2 gives details of bolt positions and clearances required. Cut 4" (100mm) to 6" (150mm) square holes in the concrete and with bolts in position run with liquid cement to fix. A good wood floor is satisfactory and coach screws may then be used.

IMPORTANT.

The level of the machine should be checked with a spirit level. Place the level across the tables in two directions and insert packing shims as necessary under the bolt holes and midway between the bolt holes for extra support. With the top tenon head in its lowest position place the level on the slide both horizontally across the top and vertically on the side and use packing shims as described above to level. Check the table level again before fixing the machine. After final fixing check the level once more to ensure that no distortion has taken place.

WIRING.

For cabling instructions see page 34 and wiring diagrams D. 749 on page 35 for motors on 50 cycles and D. 598 on page 36 for motors on 60 cycles.

DETAILS OF OPTIONAL EXTRAS.

Bottom scribing or cope spindle with 2 H. P. motor, built in control gear and cutterblock with cutters.

Top scribing or cope spindle with 2 H. P. motor, built in control gear and cutterblock with cutters.

Adjustable rear cut off saw with 2 H. P. motor, built in control gear, 14" saw and saw guard.

BALL BEARING LIST

Makers' Number	Size			Number Per Machine	Where used on Machine
	Bore	Outside Diameter	Width		
SK F. RLS. 7	$\frac{7}{8}$ "	2"	$\frac{9}{16}$ "	4	Table rollers
SK F. 0.8. Thrust Washer	1"	$1\frac{3}{4}$ "	$\frac{5}{8}$ "	2	1 - Top tenon vertical adjusting screw 1 - Bottom tenon vertical adjusting screw
SK F. 2309F	45mm	100mm	36mm	2	1 - Cutterblock end top tenon head 1 - Cutterblock end bottom tenon head
SK F. RM10F	$1\frac{1}{4}$ "	$3\frac{1}{8}$ "	$\frac{7}{8}$ "	2	1 - Tail end top tenon head 1 - Tail end bottom tenon head
SK F. RM12F	$1\frac{1}{2}$ "	$3\frac{3}{4}$ "	$\frac{15}{16}$ "	2	1 - Cutterblock end top scriber 1 - Cutterblock end bottom scriber
SK F. RL10F.	$1\frac{1}{4}$ "	$2\frac{3}{4}$ "	$\frac{11}{16}$ "	2	1 - Tail end top scriber 1 - Tail end bottom scriber
SK F. 2209F	45mm	85mm	23mm	1	Saw end cut off saw
SK F. RM8F	1"	$2\frac{1}{2}$ "	$\frac{3}{4}$ "	1	Tail end cut off saw

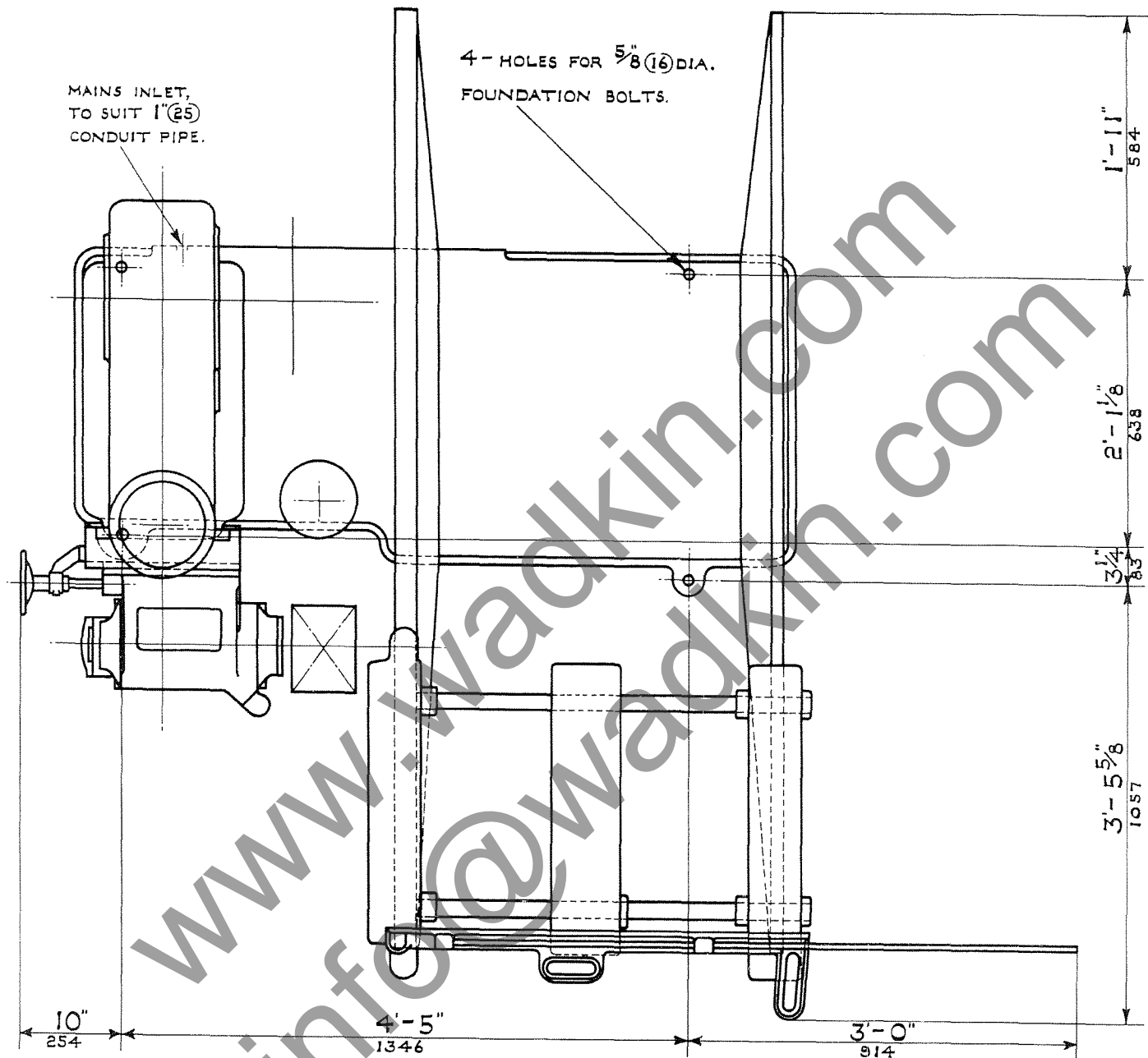

FIG. 2. PLAN OF SINGLE END TENONER. TYPE EKA.

DIMENSIONS IN FEET, INCHES AND MILLIMETRES.

LUBRICATION

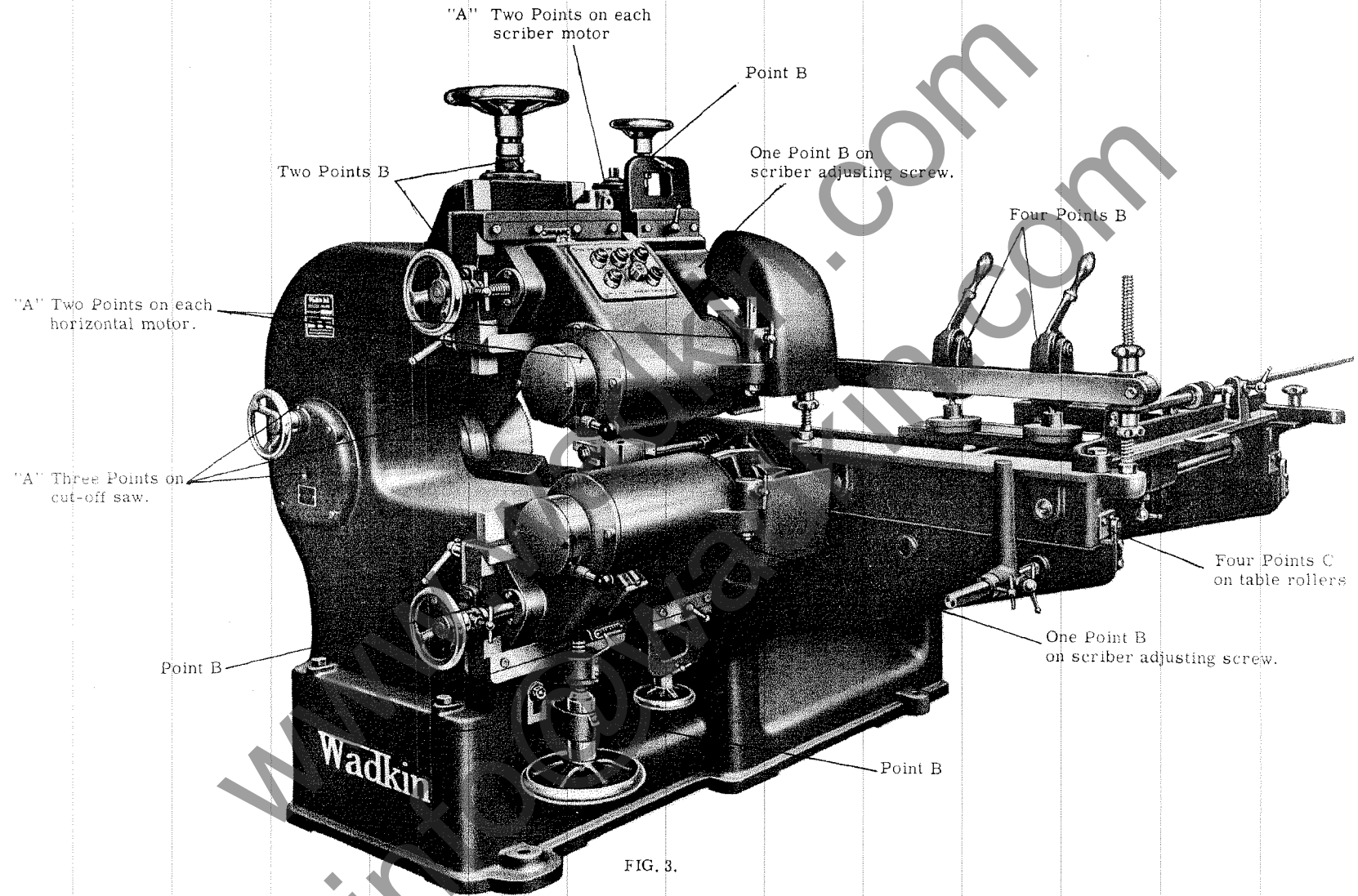

FIG. 3.

LUBRICATION (See Fig. 3)

"A" POINTS Every 3 to 6 months give 4 to 6 depressions of grease gun using Wadkin Ball Bearing Grease Grade L. 6. Note that too much lubricant will cause the bearings to run hot.

"B" POINTS Oil twice weekly using oil can or oil gun with Wadkin Machine Oil Grade L. 4.

"C" POINTS The table ball bearings are lubricated before despatch, but should be recharged with Wadkin Ball Bearing Grease Grade L. 6 every 12 months.

Every week thoroughly clean down the machine and renew the film of oil on all bright parts to prevent rust.

WADKIN RANGE OF OIL AND GREASE LUBRICANTS WITH EQUIVALENTS.

Wadkin Grade	Equivalents		
	Shell Mex and B. P. Ltd.	Mobil Oil Co. Ltd.	Caltex Lubricants
Machine Oil Grade L. 4.	Shell Vitrea Oil 33.	Mobil "Vactra" Oil (Heavy Medium)	Caltex Aleph Oil
Ball Bearing Grease Grade L. 6.	Shell Nerita Grease 3.	Mobil Grease B. R. B. No. 1.	Regal Starfak No. 2 Grease.

FIG. 4.

DIRECT FRONT VIEW
OF E. K. A. MACHINE

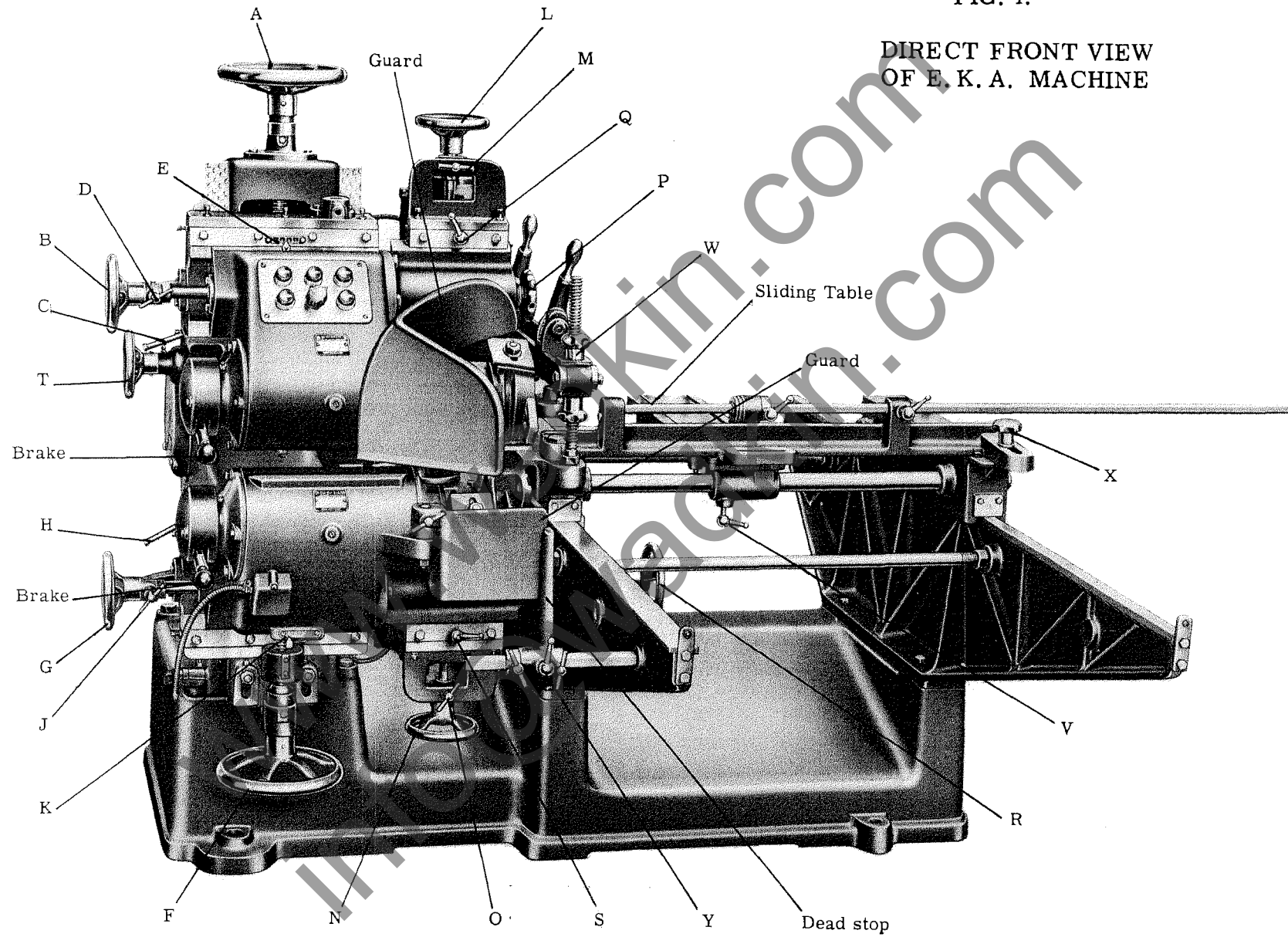

HEADSTOCK ADJUSTMENTS

TOP TENONING HEAD (See Fig. 4).

The top tenon head carriage is adjusted vertically by rotating handwheel 'A'. This movement is locked by locking handle 'C'. Horizontal adjustment is provided by rotating handwheel 'B' and it is locked by locking handle 'D'. The rule 'E' is used for setting the tenoning head horizontally. The guard moves with the tenoning head and requires no further adjustment.

NOTE - BRAKE.

The hand brake should be applied gently only after the stop button has been pressed.

BOTTOM TENONING HEAD (See Fig. 4).

The bottom tenoning head carriage is moved vertically by rotating handwheel 'F', which is locked by locking handle 'H'. Handwheel 'G' is used for horizontal adjustment, and is locked by locking handle 'J'. The tenoning head is set horizontally by rule 'K'. No adjustment need be made to the guard which is moved with the tenoning head.

NOTE - BRAKE.

The hand brake should be applied gently only after the stop button has been pressed.



Tenon with top and bottom scribe.

Angular tenon.

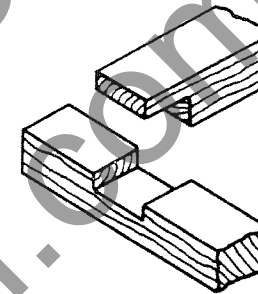

Tee-halving joint.

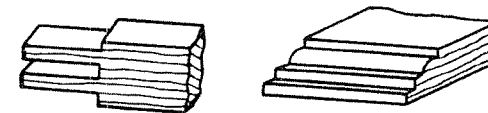

Double tenon

End moulding.



Single tenon with unequal shoulders.

HEADSTOCK ADJUSTMENTS (Continued)

SPINDLE ENDS (Tenoning Head).

The spindle end in section is shown in Fig. 5. The cutterblocks are driven with the key and locked in position with the hexagon nut. A special box spanner is provided for locking the nut. Two tommy bar holes are situated on the spindle shoulder behind the blocks for holding the spindle when locking the nut.

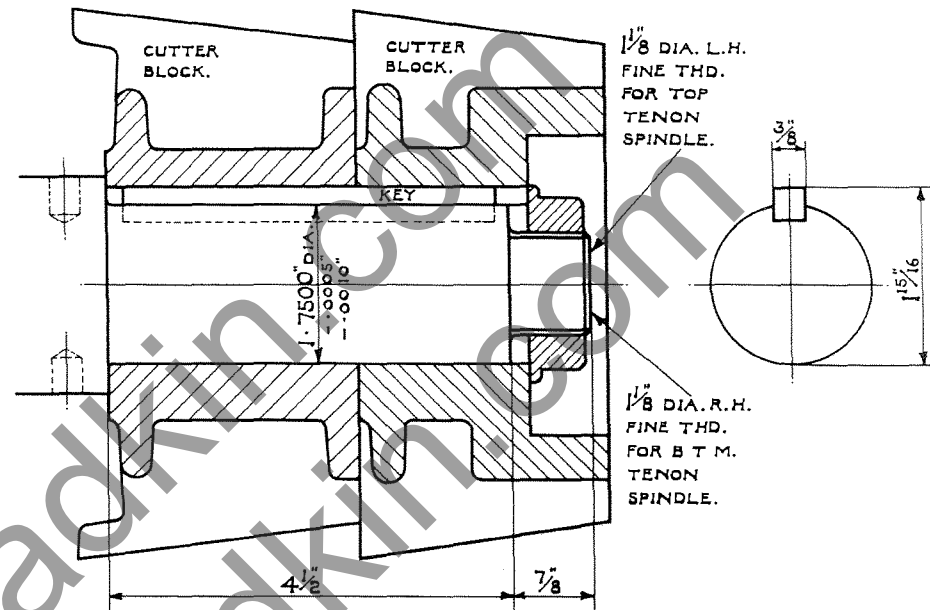

FIG.5. TENONING HEAD SPINDLE END.

TOP SCRIBING OR COPE HEAD (See Fig. 4) - OPTIONAL EXTRA.

The top scribing head is carried on a slideway fixed to the top tenoning head and will therefore move up and down when the tenoning head is adjusted. Further vertical adjustment to the scribing head is obtained by rotating handwheel 'L'. This movement is locked by locking handle 'M'. Cross adjustment to the scribing head is obtained by rotating star handwheel 'P', which is locked by locking handle 'Q'.

HEADSTOCK ADJUSTMENTS (Continued)

BOTTOM SCRIBING OR COPE HEAD (See Fig. 4) - OPTIONAL EXTRA.

The bottom scribing head is mounted and operated similar to the top head with its main adjustment taken from the bottom tenoning head. Further vertical adjustment to the head is taken from handwheel 'N' and is locked with the tee locking handle 'O'. Cross adjustment is provided by rotating handwheel 'R' and locked with locking handle 'S'.

SPINDLE ENDS (Scribing or Cope Head).

The scribing cutterblocks are mounted direct on the cutter spindle as shown in Fig. 6, and are driven with the key. They are locked in position with the locknut. The block is recessed to take the nut and a special box spanner is provided for locking this nut. A tommy bar hole is drilled through the cutter spindle on the end opposite to the cutterblock, to hold the spindle when locking or unlocking the cutterblock nut.

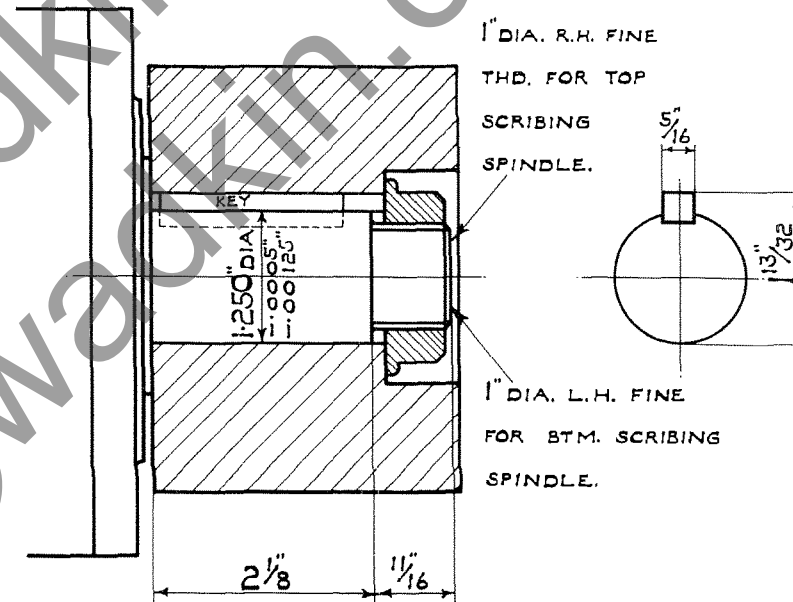

FIG. 6 SCRIBING OR COPE HEAD SPINDLE END.

HEADSTOCK ADJUSTMENTS (Continued)

CUT OFF SAW (See Figs 7 and 8) OPTIONAL EXTRA.

The handwheel 'T' is used for horizontal adjustment which is locked by the locking handle 'U'. No further adjustment need be made to the guards which move with the cut off saw.

The saw is mounted direct on the spindle as shown in Fig. 7. It is driven by the driving pin and supported by 4" diameter saw collars. The locknut secures the saw and collars up against the spindle shoulder. Two tommy bar holes are provided on the spindle shank to facilitate holding the spindle when locking or unlocking the locknut.

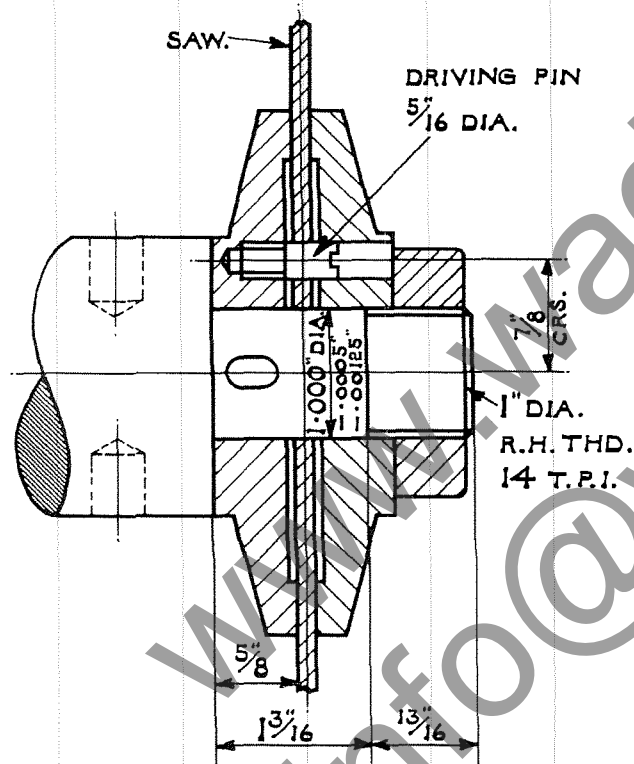

FIG. 7 CUT OFF SAW SPINDLE END.

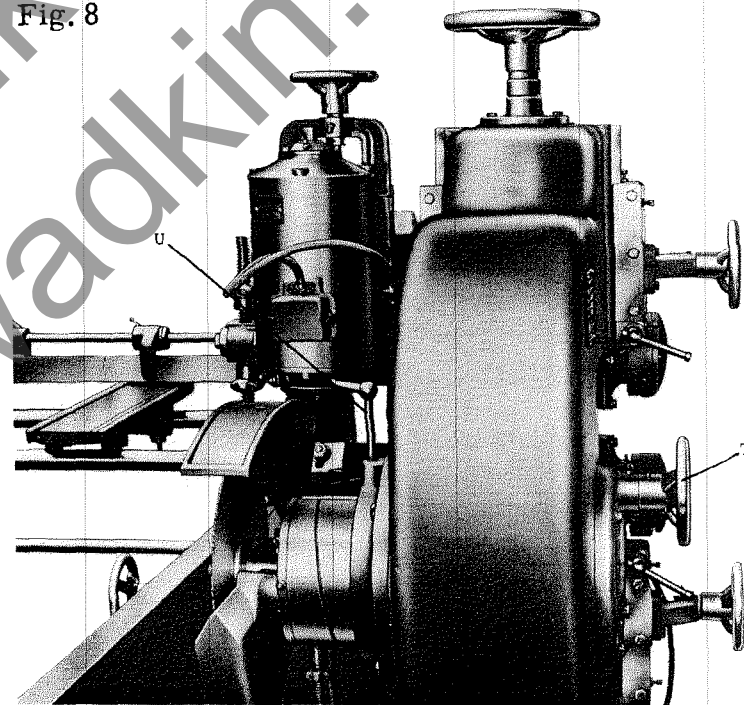

TABLE (See Fig. 4)

The table is mounted on four ball bearing rollers and is so arranged that perfect alignment with the cutterblocks is always maintained. If the tables are found to be out of line with the tenon heads re-check the level of the machine, as the floor sometimes sinks a little and disturbs the alignment.

The centre sliding table is adjustable along a steel bar in order to accommodate short stock. A spring stop runs the full length of the table for the purpose of giving the dead length between the shoulders of the tenon. Two grooves are provided to enable the operator to cut the minimum length of material by moving the stop from one groove to the other. When transferring the stop the springs have to be retained in position. The stop can be locked down making it inoperative by tightening the wing nuts under the table.

Two lever cramps are fitted which can be adjusted for various widths and thicknesses of work by screwing the four locknuts 'W' either up or down as necessary.

TABLE FENCE (See Fig. 4)

The table fence is provided with a turnover stop for use when cutting long material, allowing up to maximum length of 7'4" (2235mm) between the shoulders of the tenon. The fence can be set at angles 0° to 30° positioning by means of the holes tapped in the back table and secured by locking nut 'X'. Two holes are tapped in the centre sliding table which enables the fence to be secured at 30° and 45° .

DEAD STOP (See Fig. 4)

The dead stop is for use in conjunction with the shoulder stop on the fence for giving the length of tenon on the first cut of the stock. This stop is adjustable along a bar and can be locked where desired. The bar can be released complete with stop by using an hexagonal key to unscrew the locking nut sunk in the boss. If required the bar can be secured similarly in the second hole provided for this purpose. The stop can be allowed to fall down out of position so that it is clear of the work by unlocking locking handle 'Y'.

CUTTERHEAD ADJUSTMENT

The two tenon heads are set horizontally to give square shouldered tenons by scales and pointers set at 0 (zero) on each scale.

Unequal shouldered tenons as Fig. 10 can be produced by moving over the top head to the desired amount on the scale reading.

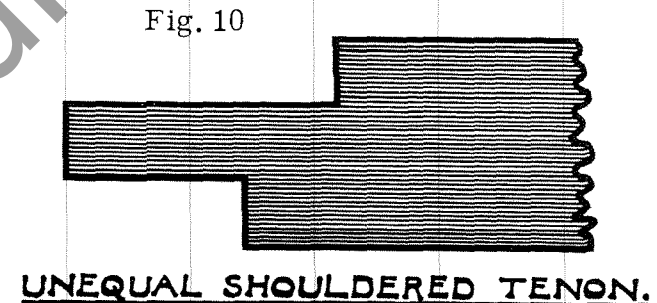
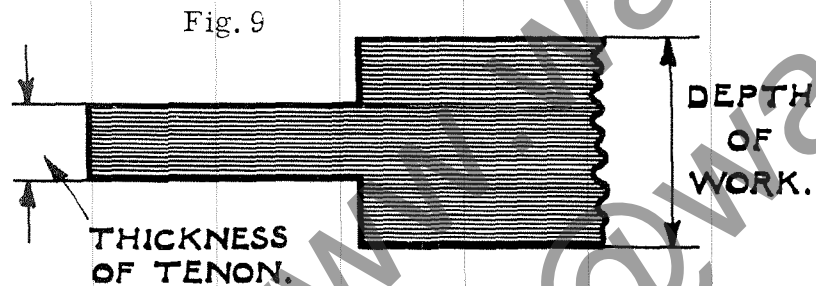

THICKNESS OF TENON.

The heads are adjusted vertically up or down to correspond with the depth of work and the cutterblocks set to give the desired thickness and position of tenon. Take care to lock slides after final setting.

ATTACHMENT FOR ADJUSTING TWO TENON HEADS TOGETHER (OPTIONAL EXTRA).

After the two tenon heads have been set to give the desired thickness of tenon and the operator wishes to vary its position in the work the attachment shown at Fig. 11 should be brought into use. Ratchet lever 'A' and adjusting screw 'B' should be assembled as illustrated. The adjusting screw is screwed into the bottom cutterhead by means of the ratchet lever, until the shoulder

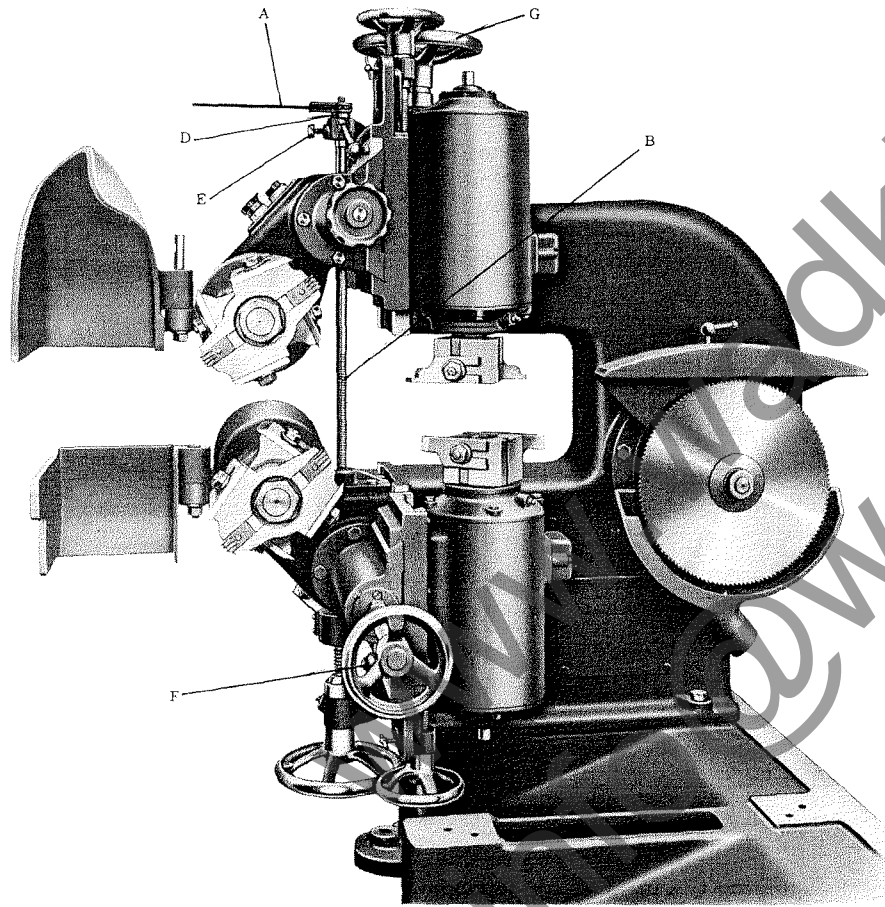
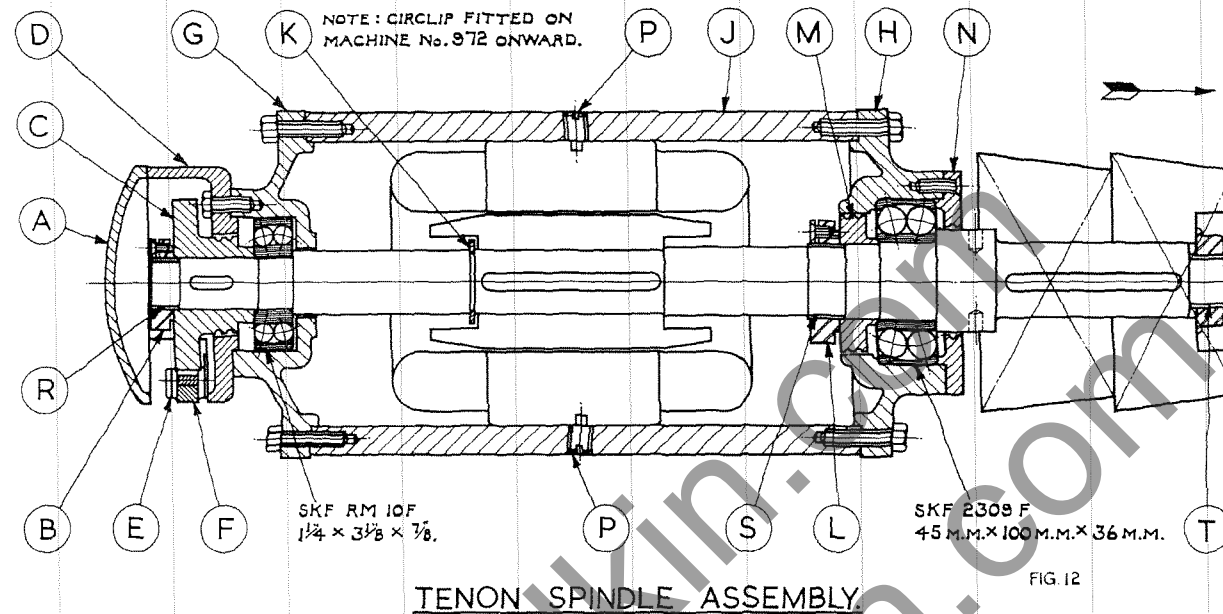

Fig. 11

of the screw 'D' is in contact with the top cutterhead and bolt 'E' locked tight to prevent movement of the adjusting screw. Before the cutterheads can be adjusted unlock the locking handles at 'C' and 'H' in Fig. 4 and loosen the two screws at 'F'. Adjust the combined heads to the required position in the work by handwheel 'G'.

The locking handles 'C' and 'H' Fig. 4 should be locked after making the adjustment and before the machine is put to use.

If required the cutterheads can be adjusted independently, whilst the adjusting screw is left in the machine by tightening screws 'F' and disengaging bolt 'E' from the groove in the screw.



METHOD OF DISMANTLING TO FIT NEW BEARINGS.

REAR BEARING

1. Remove end cover 'A'.
2. Loosen countersunk head screw in ball bearing locknut 'B' brake drum 'C' and key
3. Take off brake box 'D' complete with fulcrum pin 'E' and brake shoe 'F'.
4. Unscrew four hexagon head screws and remove bearing housing 'G' complete with bearing.
5. Knock out bearing from housing and fit replacement.
6. Reverse dismantling operation to re-assemble.

FRONT BEARING

7. Carry out operations 1, 2 and 3.
8. Unscrew four hexagon head screws securing bearing housing 'H' to carriage 'J' and knock out spindle in direction of arrow.
9. Remove circlip 'K', rotor and key.
10. Loosen countersunk head screw in front ball bearing locknut 'L' and remove locknut and grease retainer 'M'.

11. Unscrew three countersunk head screws and remove end cover 'N'.
12. Remove bearing 'H' complete with bearing from spindle.
13. Knock out bearing from housing and fit replacement.
14. Reverse dismantling operations to re-assemble.

TO REMOVE STATOR FROM CARRIAGE.

Remove two $\frac{1}{4}$ " gas pipscrews 'P' from the carriage and knock out stator.

IMPORTANT.

When replacing stator, care must be taken to avoid drilling into the windings. Maximum depth of pip-screw hole is $\frac{5}{16}$ " to the tip of drill.

TOP TENON SPINDLE E. K. A. 96A.

Thread 'R' $1\frac{1}{4}$ " fine thread. 14 T. P. I. R. H.
 Thread 'S' $1\frac{3}{4}$ " fine thread. 14 T. P. I. R. H.
 Thread 'T' $1\frac{1}{8}$ " fine thread. 14 T. P. I. L. H.

BOTTOM TENON SPINDLE E. K. A. 97A.

Thread 'R' $1\frac{1}{4}$ " fine thread. 14 T. P. I. L. H.
 Thread 'S' $1\frac{3}{4}$ " fine thread. 14 T. P. I. L. H.
 Thread 'T' $1\frac{1}{8}$ " fine thread. 14 T. P. I. R. H.

SCRIBING OR COPE SPINDLE ASSEMBLY

METHOD OF DISMANTLING TO FIT NEW BEARINGS.

REAR BEARING

1. Unscrew three hexagon head screws and remove end cover 'A'.
2. Loosen countersunk head screw in ball bearing locknut 'B' and remove locknut.
3. Remove four hexagon head screws from rear bearing housing 'C' and remove housing complete with bearing.
4. Knock out bearing from housing and fit replacement.
5. Reverse dismantling operation to re-assemble.

FRONT BEARING.

6. Unscrew three countersunk head screws and remove end cover 'D'.
7. Take off locknut 'E' and unscrew four hexagon head screws securing housing 'F' to carriage 'G'.
8. Remove bearing housing 'F' complete with bearing.
9. Knock out bearing from housing and fit replacement.
10. Reverse dismantling operations to re-assemble.

TO REMOVE ROTOR FROM CARRIAGE.

When operations 1, 2, 6, 7 and 8 have been carried out withdraw shaft from cutterblock end of the carriage and remove circlip 'H' and rotor.

TO REMOVE STATOR FROM CARRIAGE

Remove two $\frac{1}{4}$ " gas pipscrews 'J' from the carriage and knock out stator.

IMPORTANT.

When replacing stator care must be taken to avoid drilling into the windings. Maximum depth of pipscrew is $\frac{5}{16}$ " to the tip of the drill.

BOTTOM SCRIBING SPINDLE E. K. A. 418.

Thread 'K' $1\frac{1}{8}$ " fine thread. 14 T. P. I. R. H.

Thread 'L' $1\frac{1}{2}$ " fine thread. 14 T. P. I. L. H.

Thread 'M' 1" fine thread. 14 T. P. I. L. H.

TOP SCRIBING SPINDLE E. K. A. 180.

Thread 'K' $1\frac{1}{8}$ " fine thread. 14 T. P. I. L. H.

Thread 'L' $1\frac{1}{2}$ " fine thread. 14 T. P. I. R. H.

Thread 'M' 1" fine thread. 14 T. P. I. R. H.

Fig. 13

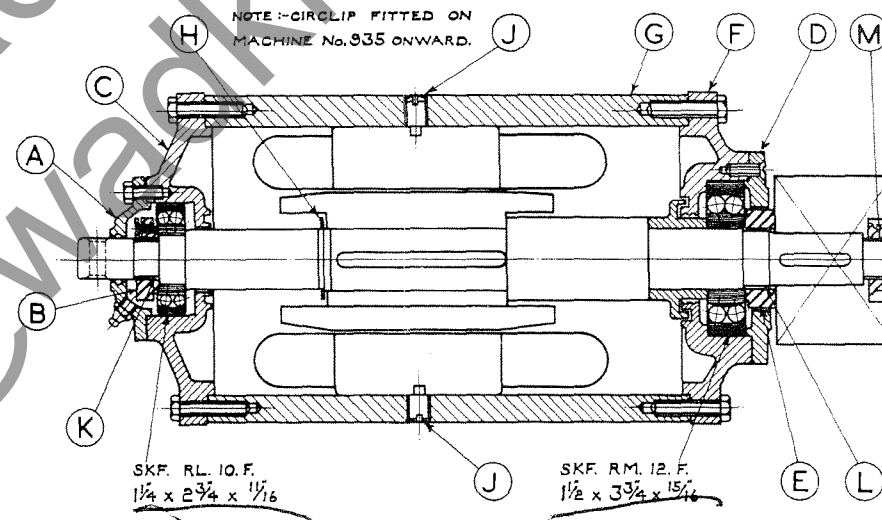

SCRIBING OR COPE SPINDLE ASSEMBLY.

CUT-OFF SAW SPINDLE ASSEMBLY

METHOD OF DISMANTLING TO FIT NEW BEARINGS.

REAR BEARING

1. Remove end cap 'A'.
2. Loosen countersunk screw in ball bearing locknut 'B' and remove locknut.
3. Remove saw flanges.
4. Remove end cover 'C' and bearing housing 'D'.
5. Withdraw shaft from saw end of frame 'E'.
6. Take bearing out of the frame and fit replacement.
7. To re-assemble reverse dismantling operation.

FRONT BEARING

8. Proceed as operations 1, 2, 3, 4 and 5 above.
9. Remove grease retainer 'F'.
10. Remove circlip 'G', rotor and key.
11. Loosen countersunk screw in ball bearing locknut 'H' and remove locknut and grease retainer 'J'.
12. Take off bearing and fit replacement.
13. To re-assemble reverse dismantling operation.

TO REMOVE STATOR FROM FRAME.

Remove $\frac{1}{4}$ " gas pipscrew 'J' from frame and knock out stator.

IMPORTANT.

When replacing stator care must be taken to avoid drilling into the windings.

Maximum depth of pipscrew hole is $\frac{5}{16}$ " to the tip of the drill.

CUT OFF SAW SPINDLE E. K. A. 281.

Thread 'L' 1" fine thread. 14 T. P. I. L. H.

Thread 'M' $1\frac{3}{4}$ " fine thread. 14 T. P. I. L. H.

Thread 'N' 1" fine thread. 14 T. P. I. R. H.

Fig. 14

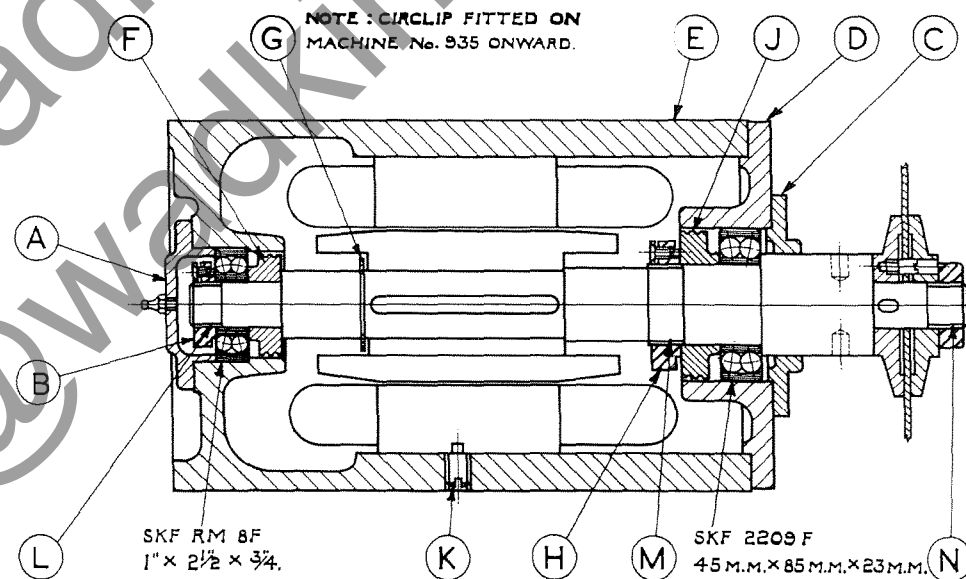

CUT OFF SAW SPINDLE ASSEMBLY.

CUTTER EQUIPMENT

TENONING CUTTERHEADS.

Tenon cutterheads are supplied as standard equipment with the machine and are complete with High Speed Steel on Iron adze cutters and high chrome steel spur cutters. The 6" long cut is broken up on the back and front half heads.

Cutterhead	Part No. of Head	Part No. of Adze Cutter	Spur Cutter
Top front half	E. K. A. 37	E. K. 150	E. K. 155
Top back half	E. K. A. 38	E. K. 150	-
Bottom front half	E. K. A. 39	E. K. 151	E. K. 155
Bottom back half	E. K. A. 40	E. K. 151	-

SCRIBING OR COPE CUTTERHEADS.

DETAILS OF CUTTERBLOCK

The cutterblocks are 4. 1/16" square section dovetail slotted and are supplied complete with one pair of High Speed Steel on Iron scribing cutters and four dovetail head bolts per block.

	Part No.	Cutters
Top scribing cutterhead	E. K. 182	V. M. 4.
Bottom scribing cutterhead	E. M. 244	V. M. 3

Spare dovetail headed bolts for use with scribing cutterblocks - Part No. Q. W. 5 with nuts Q. A. F. 24 and washers Q. A. F. 46.

Cutterblock	Cutting Circle		
	Normal	Minimum	Maximum
Standard tenon cutterblocks	8½"	-	-
Square block on scribing spindles	7¼"	6¾"	9"
Square block on tenon spindles	8¼"	8"	10"

For range of cutters for use on scribing heads see V. M. range in Section C, Page 10, of our Tools and Accessories Catalogue No. 745.

CUT OFF SAW

Standard cut off saw supplied for use on this machine is 14" diameter, Part No. Q. S. 5.

CUTTER EQUIPMENT

MOULDING.

By fitting a 5" square x $3\frac{1}{2}$ " long cutterblock Q.W. 15, Fig. 15 on the horizontal tenoning spindles a wide range of moulding can be carried out. A making up collar Q.W. 11 and four dovetail bolts and nuts are supplied. The cutterblock is secured to the spindle by the locknut. Longer cutterblocks can be made specially to suit customer's requirements.

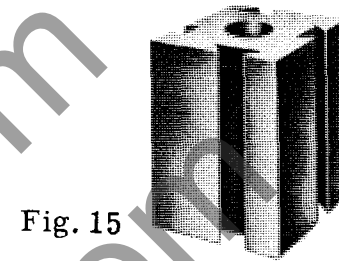

Fig. 15

TRENCHING AND GROOVING HEADS.

The type of head supplied for use on top tenon spindle is shown in Fig. 16 and is provided with side or spur cutters to give clean shoulders in the grooves. It can be quickly adjusted to cut any width of groove within its range by means of two set screws which lock direct onto the key in the machine spindle. Three sizes of head are made to cut grooves as follows :-

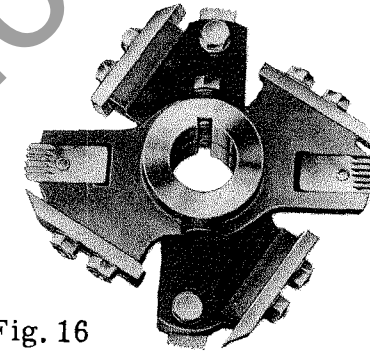

Fig. 16

11" diameter cutting circle

Head J. P. 468 for grooves $\frac{3}{16}$ " to $\frac{11}{16}$ " wide up to $\frac{9}{16}$ " deep.

Head J. P. 460 for grooves $\frac{1}{4}$ " to $1\frac{7}{16}$ " wide up to $1\frac{1}{4}$ " deep.

Head J. P. 464 for grooves $1\frac{3}{8}$ " to $2\frac{1}{2}$ " wide up to $1\frac{1}{4}$ " deep.

CUTTER EQUIPMENT

TRENCHING AND GROOVING HEADS.

Two types of wobble saw units which can be fitted on bottom scribing spindles are shown in Figs. 17 and 18. The No. 1 light type with a maximum diameter of 14" is mounted on a loose screwed spindle and two locknuts are required to secure the saw on the spindle. The heavy type wobbling saw is locked on the spindle by a single locknut, but its maximum diameter is 12". Both wobble saw units can be quickly adjusted for cutting grooves between the limits of $\frac{1}{8}$ " full to $\frac{3}{4}$ " wide.

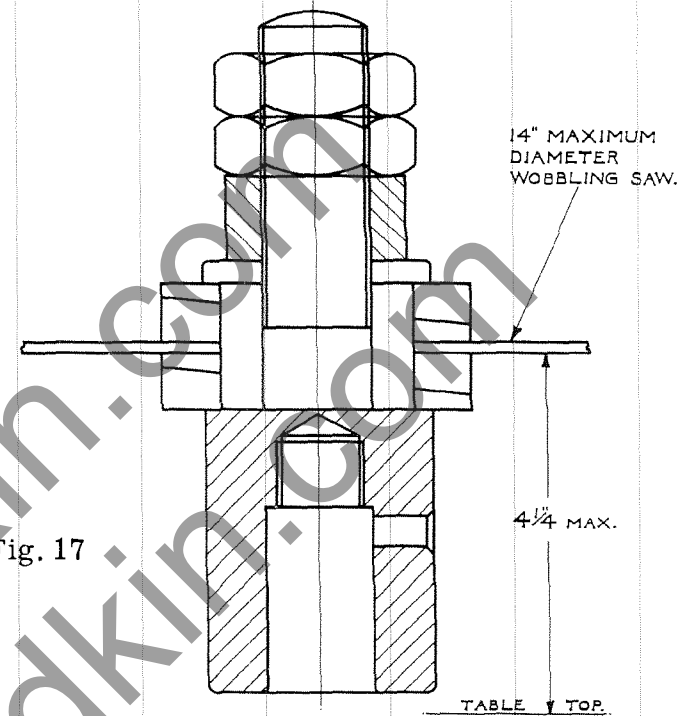

Fig. 17

No. 1 LIGHT TYPE WOBBLE SAW UNIT MOUNTED ON LOOSE SCREWED SPINDLE FITTED TO BOTTOM SCRIBING SPINDLE.

A No. 2 light type wobble saw unit can be supplied for fitting on top horizontal spindle. Its maximum diameter is 12" and can be quickly adjusted for cutting grooves between the limits of $\frac{1}{8}$ " full to $1\frac{3}{4}$ " wide. A special guard is fitted for this wobble saw.

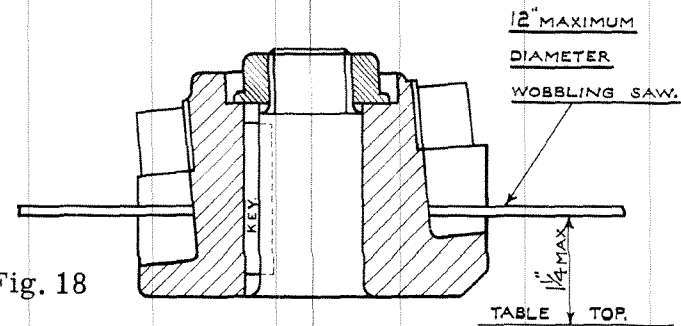

Fig. 18

HEAVY TYPE WOBBLING SAW FITTED ON BOTTOM SCRIBING SPINDLE.

CUTTER EQUIPMENT

Fig. 19
DADO HEADS.

The Dado Head is made up in sets and each set consists of two outside cutters, $\frac{1}{8}$ " thick, and several inside cutters of various thicknesses as illustrated in Fig. 19. A Dado Head mounted on the top tenon spindle is shown in Fig. 20. Sets are available for cutting grooves up to a maximum of 2" wide. Depending on the type of work cutters up to a maximum of 12" diameter can be used. The Dado Head gives a smooth finish, but each cutter has to be placed on the spindle separately and the making up collar and outside cutter taken off and replaced when adjustments to width are necessary. For quick set up and easy maintenance the expanding head illustrated in Fig. 16 is recommended.

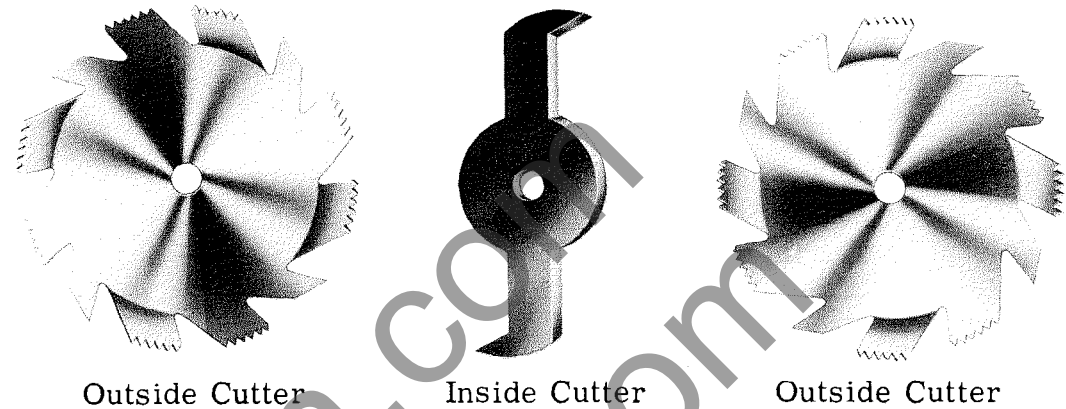

Outside Cutter

Inside Cutter

Outside Cutter

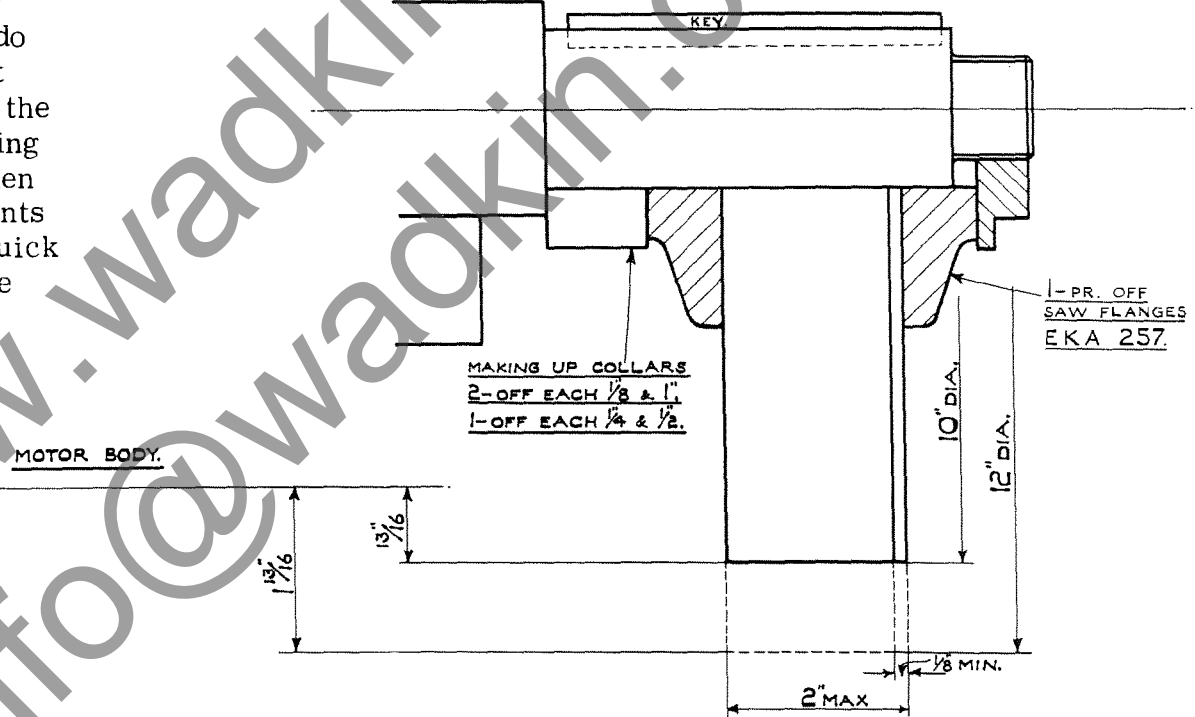

FIG. 20. No. 6. SET DADO HEAD ON TOP TENON SPINDLE.

SPECIAL CUT-OFF SAW.

If desired a plate saw Q. S. 25 fitted direct on the spindle of the top tenon head as shown in Fig. 21 can be used in lieu of the standard cut off saw unit. Two making up collars E. K. A. 258 are fitted on the spindle then two saw flanges E. K. A. 257 holding the saw. A locknut is used to secure the saw on the spindle. A special guard is fitted when this cut off saw is supplied.

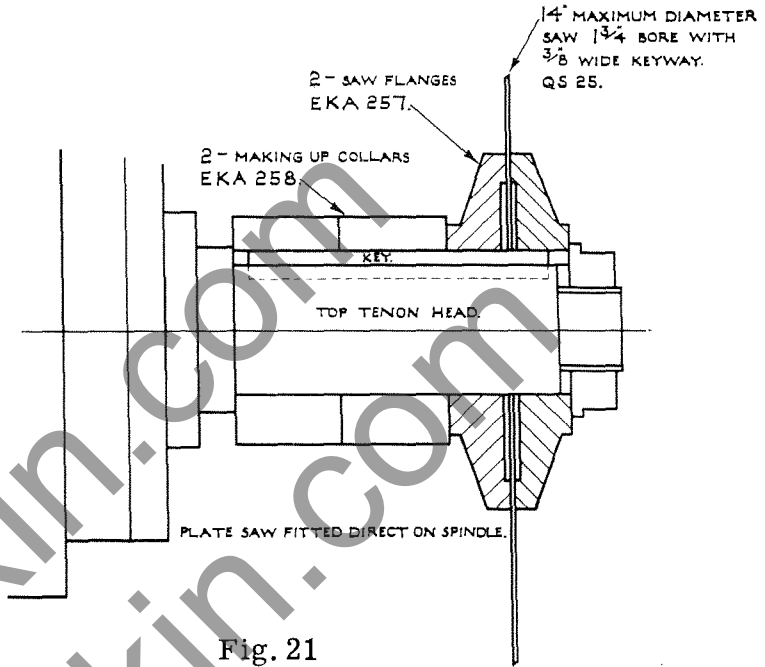

Fig. 21

INSERTED TOOTH GROOVING SAWS.

High speed steel inserted tooth grooving saws, as shown in Fig. 22, are supplied for working of narrow grooves, i. e. $\frac{1}{8}$ " up to approximately $\frac{1}{2}$ " wide, where an accurate and clean groove is required. The saws have a very long life and the teeth can be renewed when worn out. Where necessary Tungsten Carbide tipped saws can be supplied for working plywood, etc. Inserted tooth grooving saws can be supplied for fitting on either the top tenon spindle or on the top or bottom scribing spindles. A spacing collar and sleeve are provided as necessary when this saw is supplied. Set ups can be supplied to suit customer's own particular work, in which case samples or a dimensional sketch of work to be produced should be sent to us when enquiring.

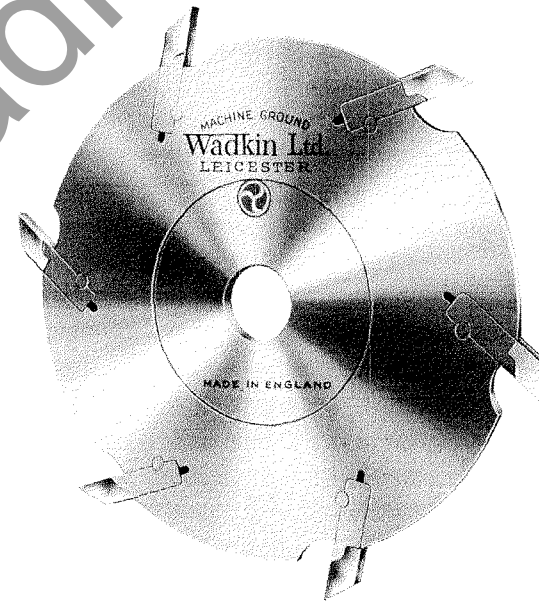
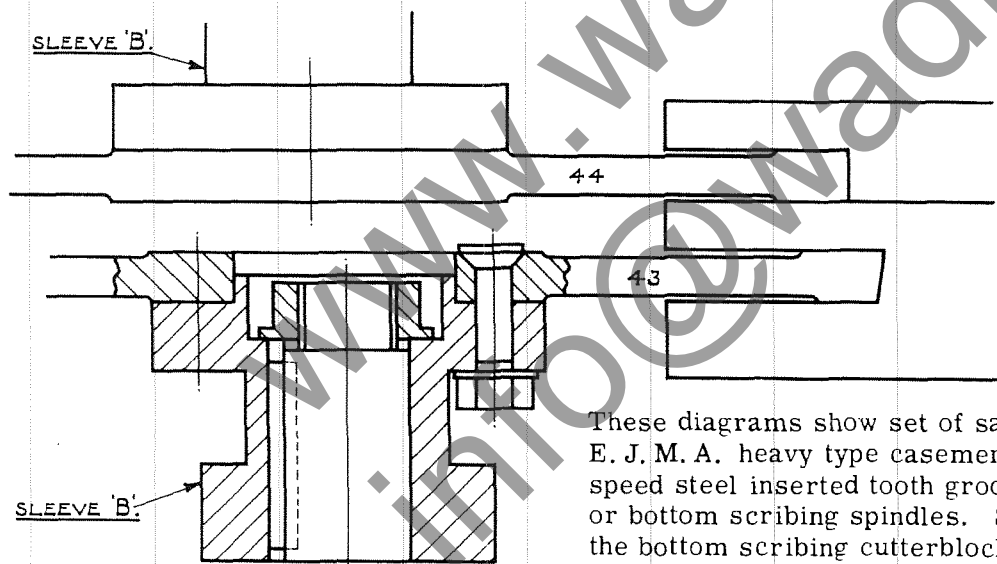
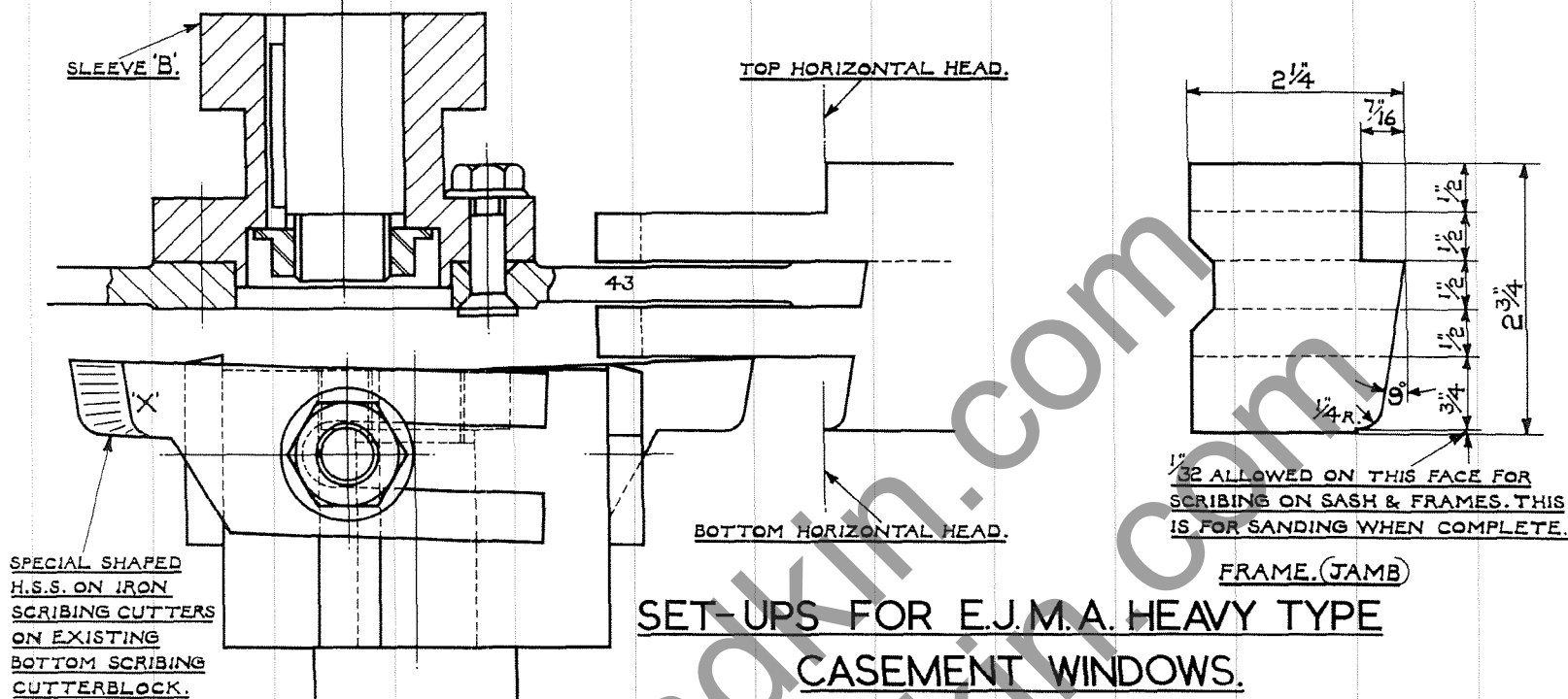
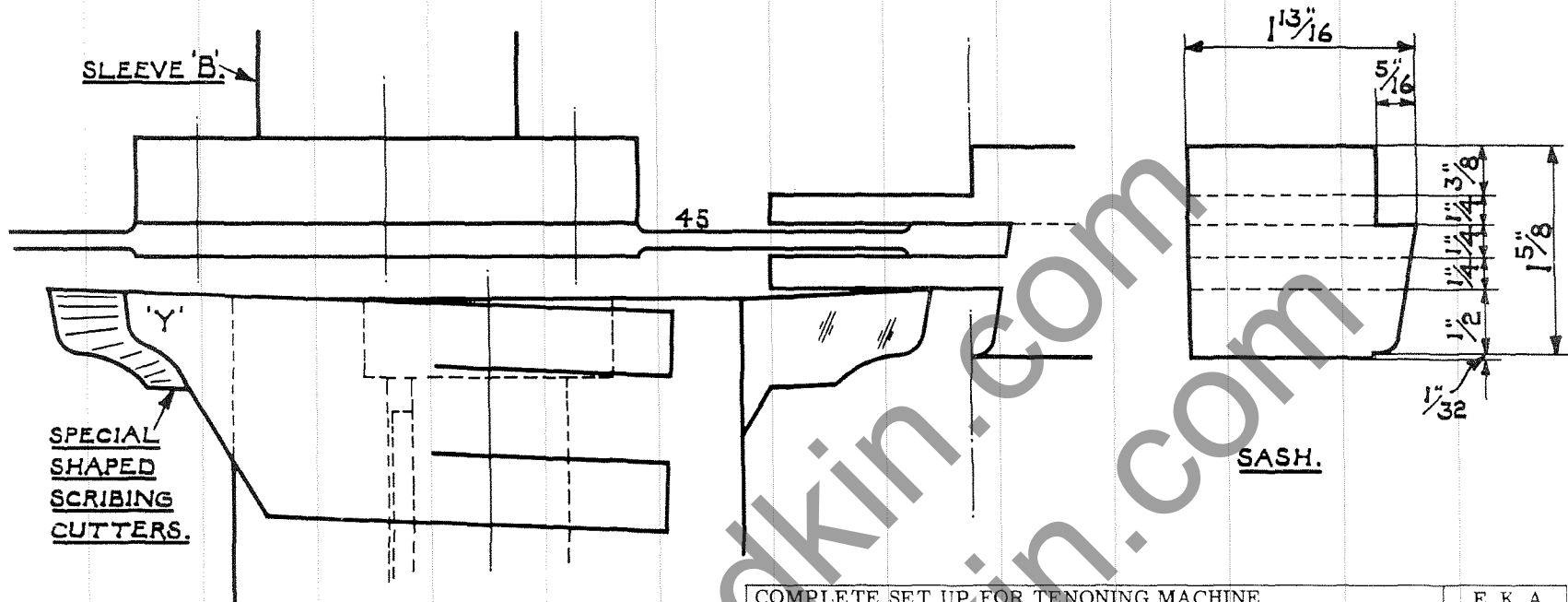

Fig. 22



These diagrams show set of saws and cutters for working frames and sashes of E. J. M. A. heavy type casement windows. The grooving is worked using high speed steel inserted tooth grooving saws mounted on special sleeves fitted on top or bottom scribing spindles. Shaped scribing cutters can be supplied for use on the bottom scribing cutterblock. Complete set ups can be supplied to suit customers own particular joints, please send detailed sketch or samples when enquiring.



SPECIAL SHAPED SCRIBING CUTTERS.

COMPLETE SET UP FOR TENONING MACHINE		E. K. A.
Sleeves		'B' 2-off
Saws Nos. 43, 44, 45 and 46 (as drawing)		1-off each
Special high speed steel on iron scribing cutters 'X' (as drawing)		4-off
Special high speed steel on iron scribing cutters 'Y' (as drawing)		4-off

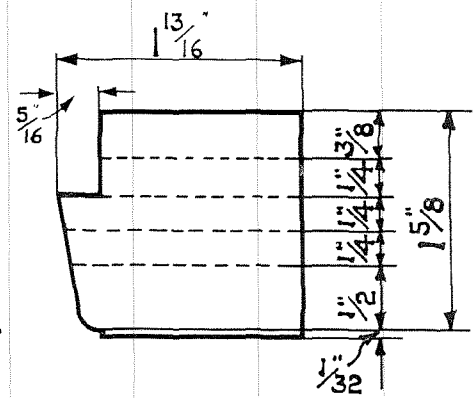
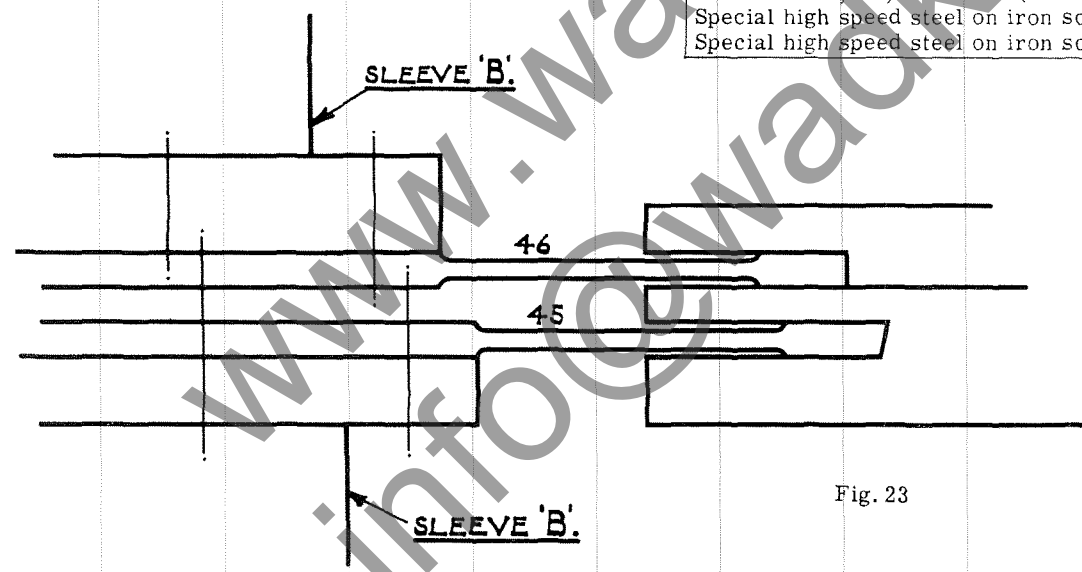

Fig. 23

TENON BLOCK ADZE CUTTER GRINDING ATTACHMENT

USED ON THE WADKIN UNIVERSAL CUTTER GRINDER, TYPE N.H.

This attachment provides an accurate method of grinding and maintaining the correct shape of the adze cutters by mechanical methods. It consists of a fixed finger working along the edge of the cutter, the cutterblock assembly being mounted on the swivelling table. The standard arbor supplied with the attachment will accommodate any Wadkin tenon block.

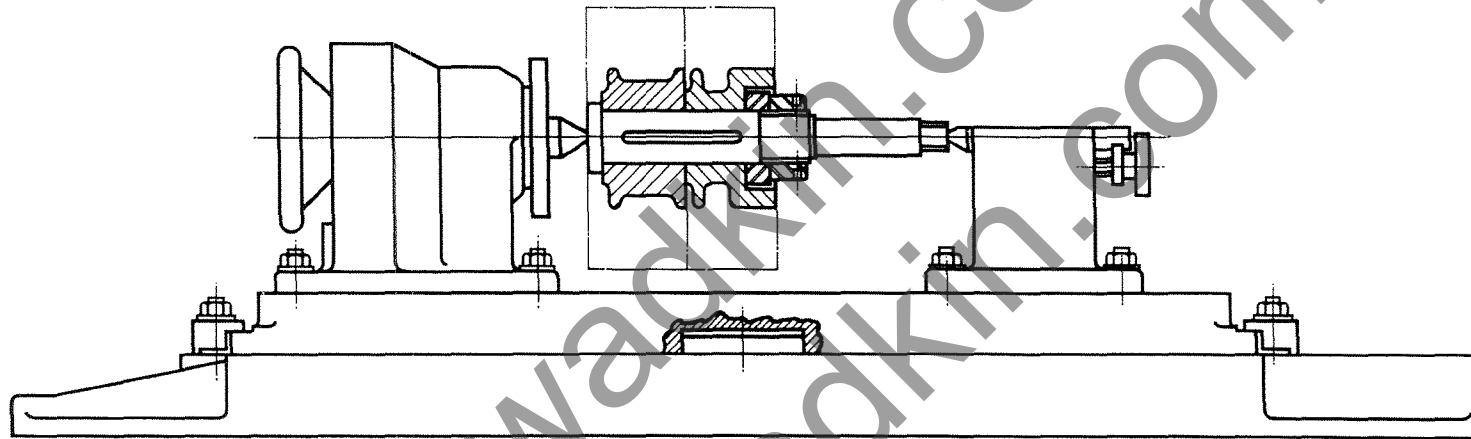

Fig. 24

Fig. 24 shows the mounting of the blocks from the E. K. A. machine, both halves of the block being mounted.

The swivelling table is mounted on the machine table, dividing head and tailstock then being placed in position.

A No. 4 Morse taper dead centre is now fitted into the bore of the dividing head, the arbor complete with blocks being mounted between the two centres in the head and tailstock giving the complete table assembly as shown in Fig. 24. The dividing head will not be used for indexing purposes so this can be locked. The screws holding the spur cutters in the tenon blocks should be loosened and the spur cutters dropped below the cutting circle diameter. This is to prevent the spur cutters fouling the grinding wheel during the grinding operation.

TENON BLOCK ADZE CUTTER GRINDING ATTACHMENT (Continued)

The finger assembly is now set up as shown in Fig. 25. The tip of the finger should be set approximately $\frac{3}{4}$ " below the centre of the wheel, on the cutting side of the wheel (left-hand side with the wheel running clockwise) and $\frac{1}{32}$ " away from the wheel as shown in diagram Fig. 26.

Generally, tenon blocks are made slightly conical and due to this the swivelling table must be set over to give this coned effect, as shown exaggerated in Figs. 27 and 28. The amount that the table is set over depends upon the make of block, but for Wadkin blocks the amount is one division of the scale on the left-hand side of the swivelling table, equal to a movement of $\frac{1}{16}$ ".

The direction in which the table is set over depends upon which way the block is coned. On all Wadkin blocks the spur cutter end of the block is the bigger diameter, therefore the settings are as shown in Figs. 27 and 28.

NOTE. - It is recommended that when a block has been ground, tried on the setting-up stand and found correct, that the position of the swivelling table relative to the machine table be marked by scribe lines to facilitate easier and quicker set-ups for subsequent regrinds.

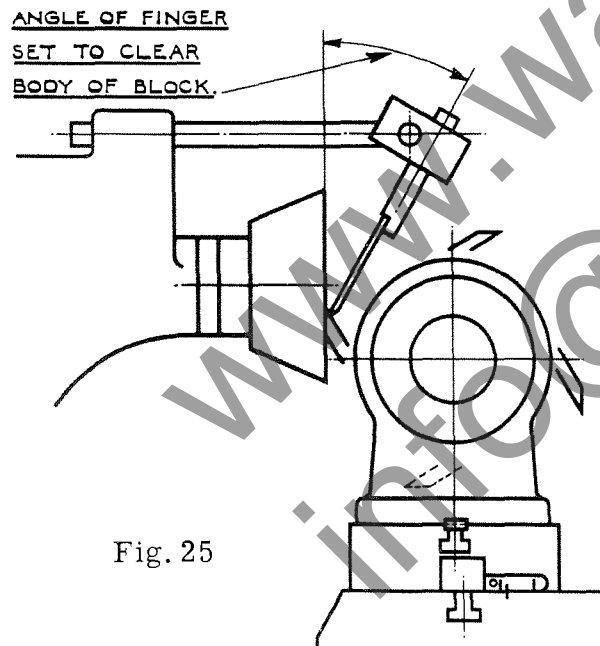

Fig. 25

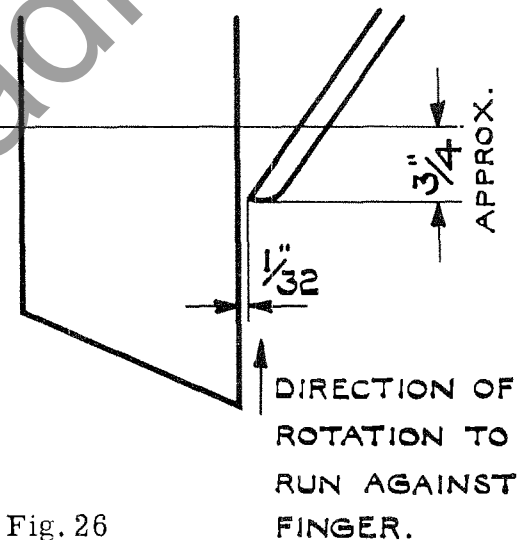

Fig. 26

TENON BLOCK ADZE CUTTER GRINDING ATTACHMENT (Continued)

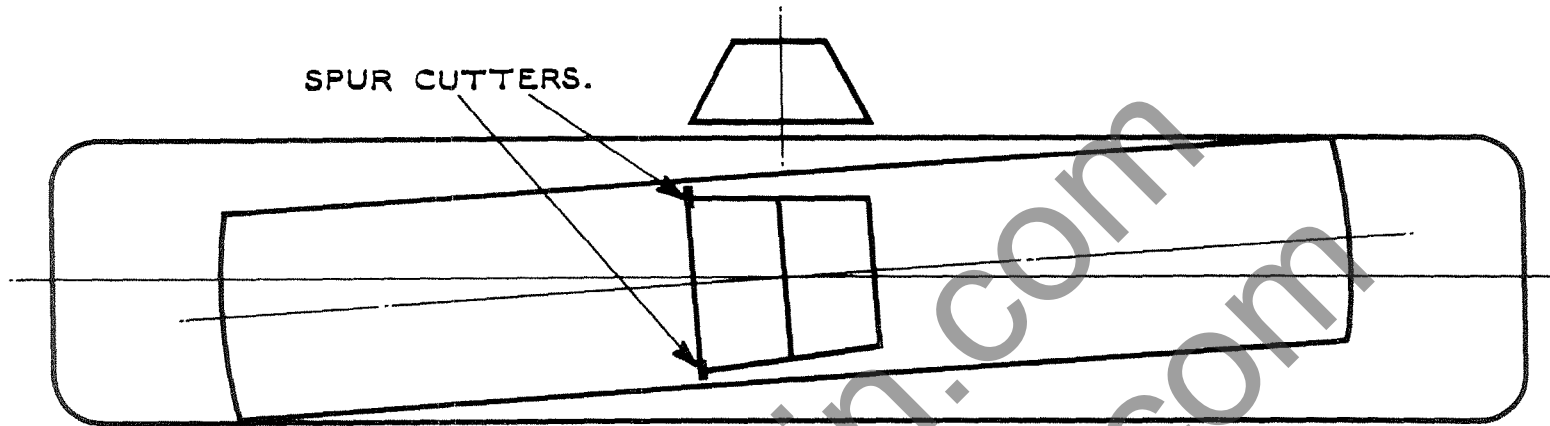

Fig. 27

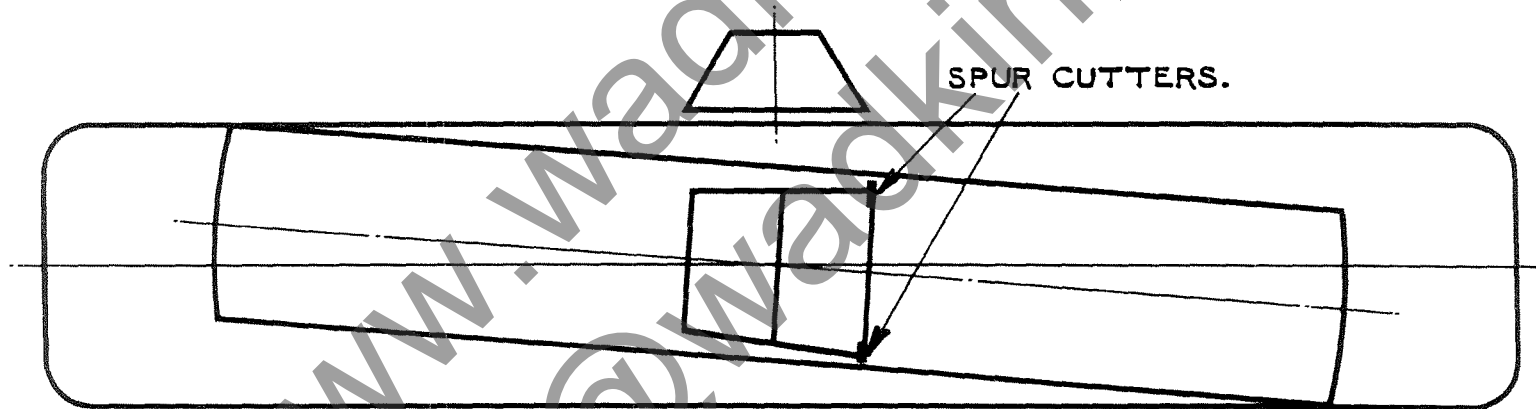

FIG. 28

The edge of the first knife should now be set between the finger and the wheel, and by means of the rise and fall and cross traverse to table, the knife should be brought into a position to give the correct grinding angle. The knives are now ready to be ground. Keeping the left hand on the tenon block and pressing the knife lightly back on to the finger, the right hand is used to traverse the table longitudinally, as shown in Fig. 30.

TENON BLOCK ADZE CUTTER GRINDING ATTACHMENT (Continued)

Take an initial roughing cut of one or one-and-a-half thousandths of an inch on one knife, turn the block round to the next knife and take the same cut, proceeding thus until all knives have been ground. After grinding completely round the block, take successive light roughing cuts until all knives are sharpened. On the roughing cuts use a rapid table traverse. On the finishing pass, reduce the cut to one-half thousandth of an inch and use a slow table traverse to ensure a keen cutting edge and uniform blade height. Finally check the setting of the knives on the tenon block setting stand.

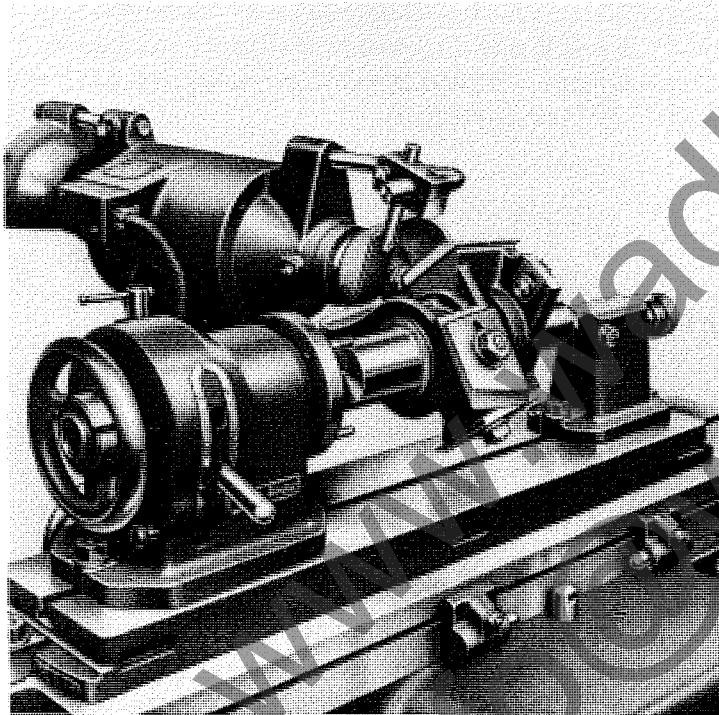

FIG. 29. Showing the tenon blocks set up for grinding.

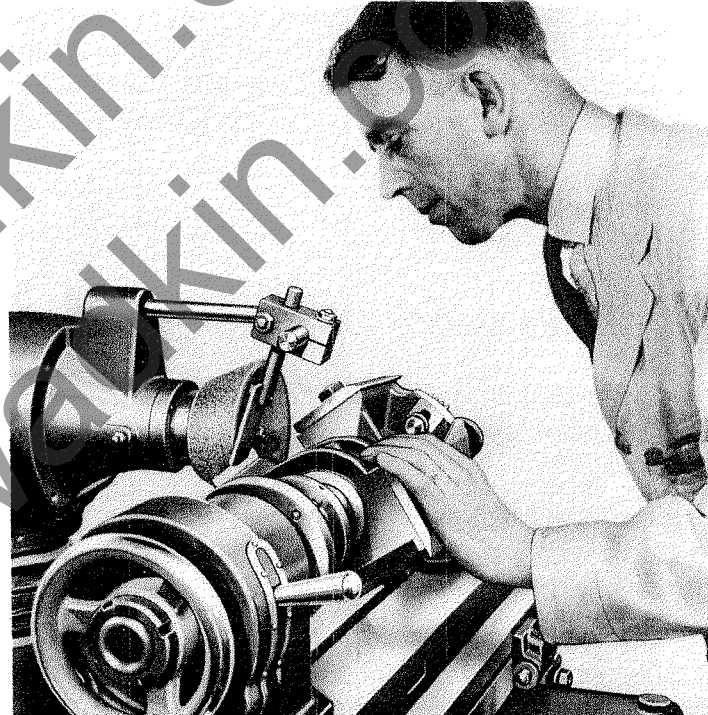

FIG. 30. Showing the actual operation of grinding, indicating the best position for the operator.

FREE HAND METHOD OF GRINDING TENON CUTTERS TO GAUGE.

The template supplied with the machine is used when free hand grinding tenon cutters to gauge. It is necessary to ensure that the cutting edge of the cutter is shaped correct to the template, otherwise the tenon will not be flat or parallel.

The correct cutter angle of 30° should be maintained. This is to give the correct strength to the cutting edge and clearance on the cutting track.

Hollow grinding is recommended wherever possible, as a perfect cutting edge is more easily obtained by stoning. When stoning a flat ground cutter a good edge is more difficult to obtain due to the tendency to rock the stone and leave a convex face. When hollow grinding is carried out the angle of the cutting edge should be kept as near 30° as possible.

SETTING UP STAND T. S. S. FOR TENONING HEADS.

Setting up the curved Adze cutters on horizontal tenoning heads can be considerably simplified and speeded up by the use of this stand. A making up collar is supplied for use with the outside head.

On the stand are engraved a series of curves representing the cutting track of cutters used on various machines. The wood block is first adjusted so that it is in line with the appropriate curve.

Fit the inside head on the arbor up against the locking collar as shown in Fig. 31. The head of the cutterblock determines on which side it is fitted. Rotate the cutterblock to check that as the edge of the cutter passes the centre of the wood block it just touches all along. The cutter will need adjustment either if it will not pass the wood or if there is a gap between the cutter and the wood.

SETTING UP STAND T.S.S. FOR TENONING HEADS (Continued)

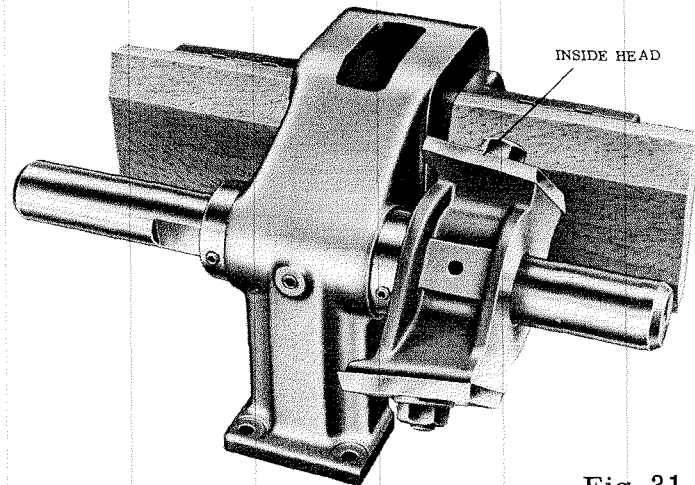

Fig. 31

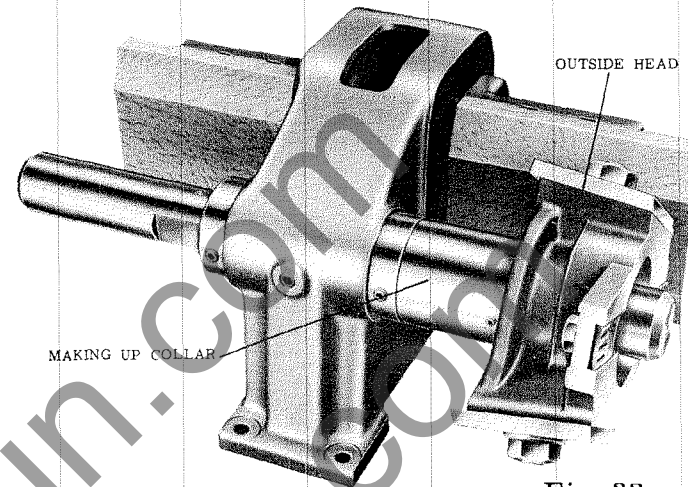

Fig. 32

After setting remove the inside head and place the making up collar on the arbor and fit on the outside head as shown in Fig. 32. The making up collar is necessary because the heads are not parallel but taper very slightly, and if the outside head was set in the same position as the inside head it would cause a step in the tenon. With the outside head in position, set as described above for the inside head.

The heads are slightly tapered to obtain undercutting of the shoulders as described below.

CUT OF THE HEADS.

The cut of the heads is shown in Fig. 33. The undercutting of the shoulder, which is exaggerated, is necessary to ensure clean fitting shoulders when cramped together.

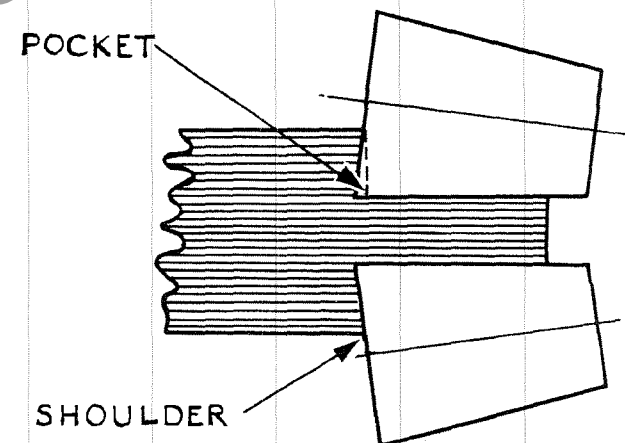

Fig. 33

CUTTER GRINDING

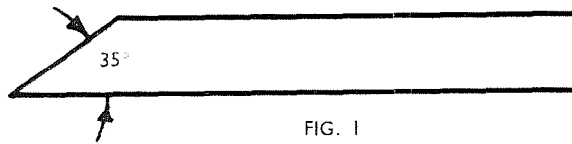

FIG. 1

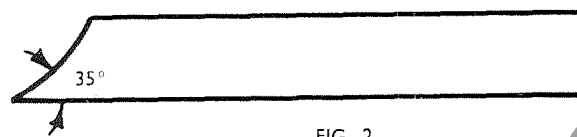
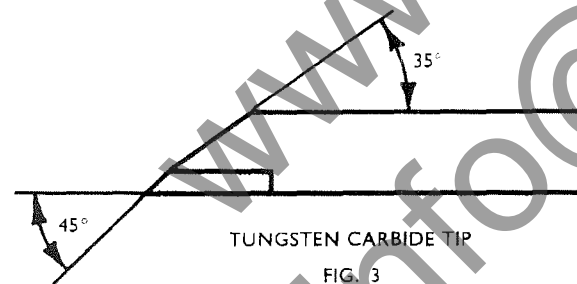

FIG. 2



TUNGSTEN CARBIDE TIP

FIG. 3

Cutters should be ground carefully avoiding any overheating as this will crack or soften cutters so that they will not stand up to the work. A solution of soluble oil and water should be handy and the cutters should be held in this occasionally to cool them. This solution will also prevent rusting. Cutters should never be allowed to become discoloured during grinding, as this indicates overheating.

The correct cutter angle of 35° for most cutters should be maintained, this is to give the correct strength to the cutting edge. When hollow grinding is carried out, the angle of the cutting edge should be kept as near 35° as possible, see Figs. 1 and 2.

Hollow grinding is recommended wherever possible, as a perfect cutting edge is more easily obtained by stoning. When stoning a flat ground cutter a good edge is more difficult to obtain due to the tendency to rock the stone and leave a convex face.

Good open grain wheels should be used and not allowed to become glazed, as this will cause excessive heat.

About 12" diameter for new wheels gives the best radius for the hollow grind and the economic life. 8" wheels used down to 6" leave the grind too hollow.

Tungsten carbide tipped cutters should be purchased to the shape required and only need re-grinding. In this case cutters should be relieved at 35° on steel and the tips finished with a diamond impregnated wheel at 45° as shown, using only very light cuts to prevent cracking.

The diamond wheel should not be allowed to touch the steel backing as this clogs the wheel and causes excessive heat. Where available a copious flow of coolant should be used. They may be honed with a diamond hand lap, as the cutter becomes dull, until a re-grind is necessary.

A thin oil lubricant should be used on the hand lap.

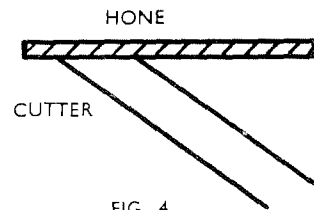

FIG. 4

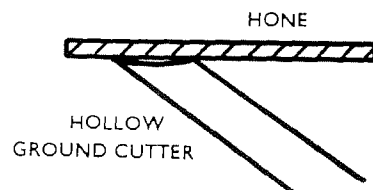

FIG. 5

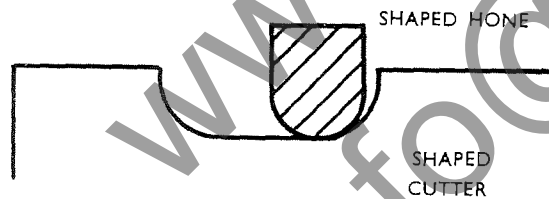

FIG. 6

HONING.

Cutters must have a razor sharp cutting edge before commencing to cut. To obtain this edge it is necessary to hone the cutters using a 142 carborundum slip stone. This will ensure a good finish on the wood and an easy feed. Dull cutters give a poor, rough and plucked out finish and make it difficult to feed the job past the cutters. Honing should be done by a reciprocating or rotary motion on the cutter, using a little paraffin to give "bite" to the stone. The honing stone is a much finer grit than the grindwheel and leaves a sharp keen edge. A number of honing stones of different shapes, e.g. round or square sticks will be found helpful in honing shaped cutters.

ELECTRICAL INSTALLATION INSTRUCTIONS

INSTALLATION

The cabling between the motor and control gear has been carried out by WADKIN LTD. and it is only necessary to bring the line leads to the machine for it to be put into service. This should be done as follows :

- (1) Connect the line leads to the appropriate terminals of the isolating switch. See diagram of connections. The cables should be taken to the machine in conduit and secured to the control apparatus by means of locknuts.
- (2) Ensure that the machine is connected solidly to earth.
- (3) Close the isolating switch and lower the appropriate hand lever. If the headstock motors do not rotate in the right direction, interchange any two incoming line leads.

FAILURE TO START

- (1) Electric supply is not available at the machine.
- (2) Fuses have blown or have not been fitted.
- (3) Isolating switch has not been closed.
- (4) Hand lever has not been sufficiently lowered.

STOPPAGE DURING OPERATION

- (1) Fuses have blown.
- (2) Overloads have tripped. They will reset automatically after a short time and the machine can be restarted in the usual manner.

ADJUSTMENTS

For a finer overload setting, set the load indicator to a lower value and vice-versa for a less fine setting.

GENERAL

Check the earth connection periodically. Users are recommended to display in a prominent position in the Maintenance Department, WADKIN ELECTRICAL MAINTENANCE INSTRUCTION CARD No. 356, which will be issued gratis on application.

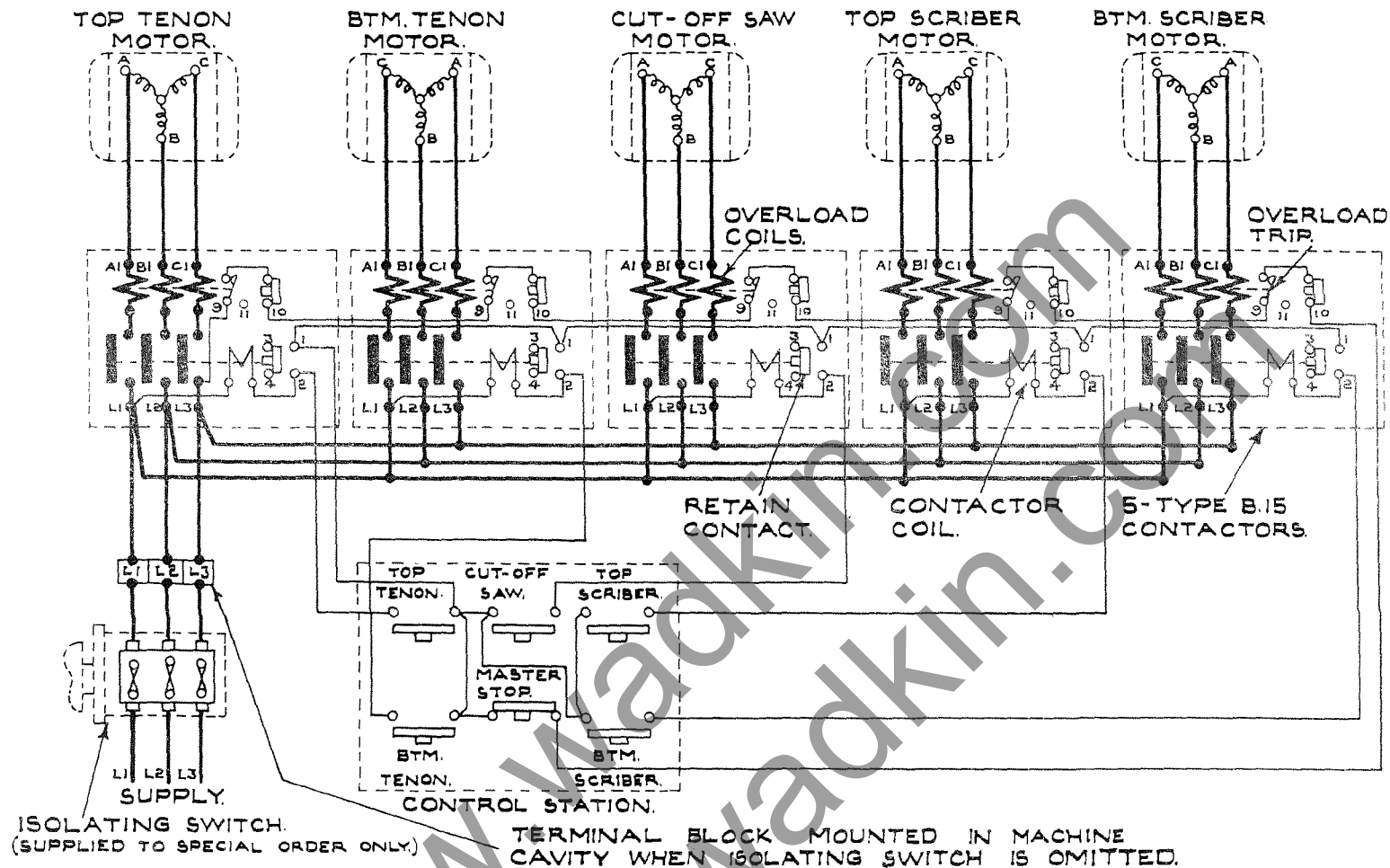

INSTALLATION INSTRUCTIONS.

FIT TRIPLE POLE ISOLATING SWITCH NEAR MACHINE UNLESS SUPPLIED BY WADKIN LTD. TO SPECIAL ORDER, SO THAT THE ELECTRICAL GEAR MAY READILY BE ISOLATED FOR INSPECTION PURPOSES. BRING SUPPLY CABLES TO ISOLATING SWITCH AND TO L1, L2, L3 AT CONTACTOR PANEL THROUGH CONDUIT WHICH SHOULD BE SCREWED INTO THE MACHINE AND SECURED BY MEANS OF LOCKNUTS. A HOLE IS PROVIDED IN THE MACHINE FRAME FOR THE CONDUIT CARRYING THE SUPPLY CABLES TO THE CONTACTORS. ENSURE THAT THE DIRECTION OF ROTATION IS CORRECT BEFORE PUTTING THE MACHINE INTO SERVICE, TO REVERSE ROTATION INTERCHANGE INCOMING SUPPLY CABLES L1 AND L3 AT ISOLATING SWITCH.

OPERATING INSTRUCTIONS.

TO START MACHINE: CLOSE ISOLATING SWITCH AND PRESS THE 'START' BUTTONS FOR HEADS WHICH ARE REQUIRED TO OPERATE. TO STOP MACHINE: PRESS 'STOP' BUTTON. TO LOCK OFF MACHINE: PRESS AND TURN 'STOP' BUTTON, THIS MUST BE RELEASED BEFORE A START CAN BE MADE.

OVERLOAD.

SHOULD THE MACHINE STOP DUE TO OVERLOAD WAIT FOR A SHORT TIME TO ALLOW THE HEATER COILS TO COOL, THEN START IN THE USUAL MANNER.

TYPE R.A. SIZE N°1 MAGNETIC STARTERS.

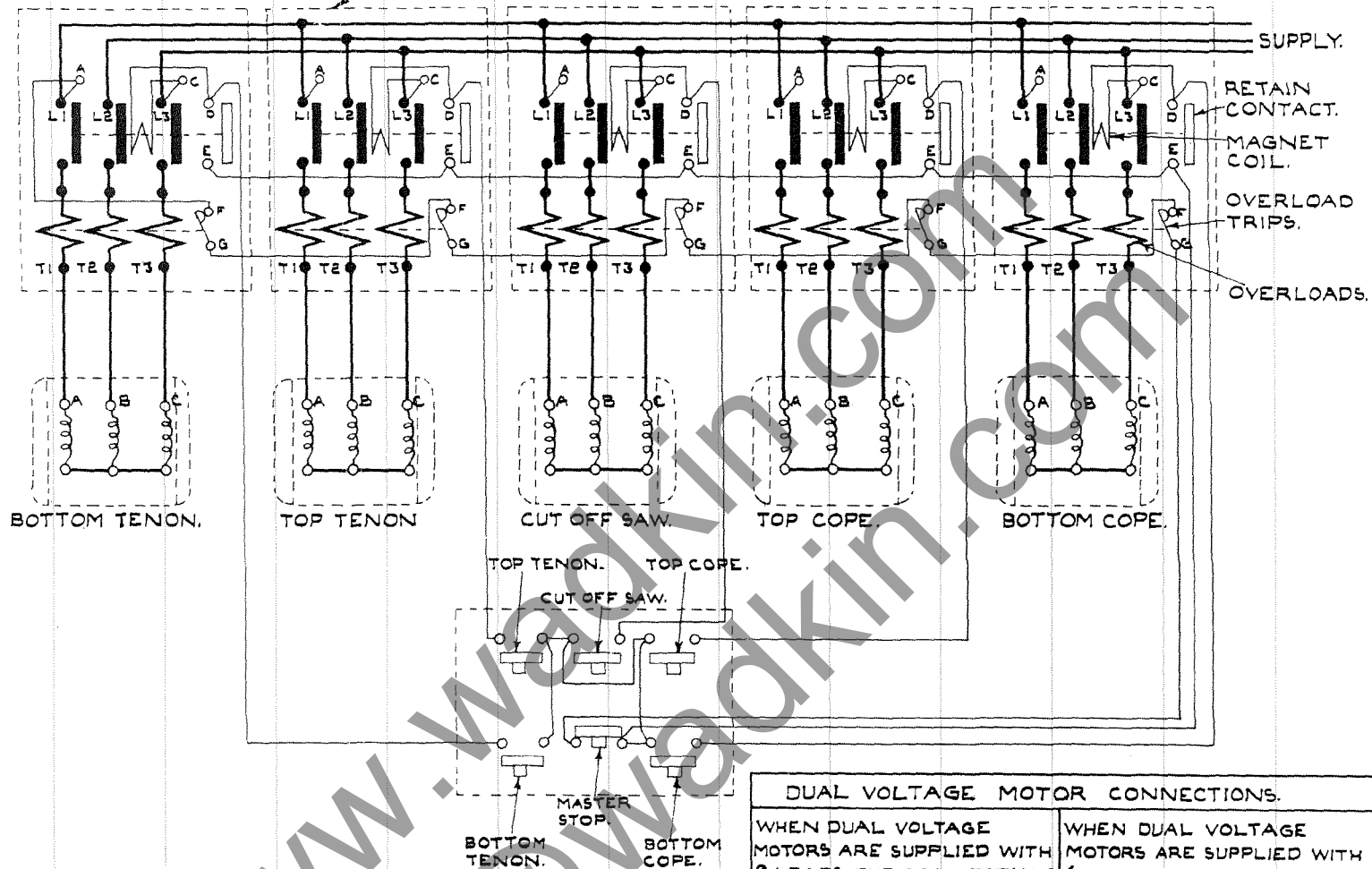

INSTALLATION INSTRUCTIONS.

FIT MAIN DISCONNECT SWITCH NEAR MACHINE SO THAT THE ELECTRICAL GEAR MAY READILY BE ISOLATED FOR INSPECTION PURPOSES. BRING SUPPLY CABLES TO MAIN DISCONNECT SWITCH AND TO L1, L2, L3 AT MAGNETIC STARTERS THROUGH CONDUIT WHICH SHOULD BE SCREWED INTO THE MACHINE AND SECURED BY MEANS OF LOCKNUTS. ENSURE THAT THE DIRECTION OF ROTATION OF THE MOTORS IS CORRECT BEFORE PUTTING THE MACHINE INTO SERVICE, TO REVERSE ROTATION INTERCHANGE SUPPLY CABLES L1 AND L3.

OVERLOAD.

SHOULD THE MACHINE STOP DUE TO OVERLOAD, WAIT FOR A SHORT TIME TO ALLOW THE HEATER COILS TO COOL THEN RESET THE TRIPS BY DEPRESSING THE PLUNGER ON THE OVERLOAD ASSEMBLIES.

DUAL VOLTAGE MOTOR CONNECTIONS.			
WHEN DUAL VOLTAGE MOTORS ARE SUPPLIED WITH 9 LEADS THE CONNECTIONS SHOWN BELOW ARE NECESSARY:- SERIES/STAR-440 VOLTS. PARALLEL/STAR-220 VOLTS.		WHEN DUAL VOLTAGE MOTORS ARE SUPPLIED WITH 6 LEADS THE CONNECTIONS SHOWN BELOW ARE NECESSARY:- STAR - 340/440 VOLTS. DELTA - 200/250 VOLTS.	
TO T1-T2-T3 AT STARTER.	TO T1-T2-T3 AT STARTER	TO T1-T2-T3 AT STARTER	TO T1-T2-T3 AT STARTER
9 LEAD MOTORS.		6 LEAD MOTORS.	



ULTRACARE

At the Cutting Edge of Industry

EKA

SINGLE END TENONER

SPARE PARTS BOOKLET



SPARE PARTS BOOKLET

CONTENTS

1. Basic ordering requirements.
2. Sample type order.
3. List of item numbers and description of item.
4. Drawing showing item numbers.

EKA

SINGLE END TENONING

MACHINE

SPARE PARTS

Should spare parts be required due to breakage or wear full particulars including the machine and test number must be given. This information is on the nameplate attached to the machine and will be similar to the picture below.

Wackin Ltd.
LECESTER ENGLAND

MACHINE SERIAL NO.	FD 6134	
MACHINE TEST NO.	7-601	
PATENT NO.		
VOLTAGE	PHASE	CYCLES
400	3	50

SEE MAINTENANCE INSTRUCTION
BOOK FOR LUBRICATION DETAILS

Please see the next page for sample detail of how to order spare parts.

SAMPLE TYPE ORDER

MACHINE: EKA

MACHINE NO: 1407

TEST NO: 68975

PARTS REQUIRED

- 1 - EKA497/EKA13 BRAKE SHOE
- 1 - EKA497/EKA56 SCREW FOR VEE STRIP
- 1 - EKA497/EKA184 ADJUSTING SCREW
- 1 - EKA497/EKA254 STUD FOR OPERATING BRAKE
- 1 - EKA497/EKA336 CLAMP SPRING

www.wadkin.com
info@wadkin.com

EKA SPARE PARTS LIST

EKA497/EKA5	BEARING BRACKET FOR CUTTER CARRIAGE
EKA497/EKA6	BEARING BRACKET FOR CUTTER CARRIAGE
EKA497/EKA10	END COVER FOR BEARING BRACKET
EKA497/EKA13	BRAKE SHOE
EKA497/EKA17/A	SCRIBING CUTTER CARRIAGE
EKA497/EKA18	BEARING BRACKET FOR CUTTER CARRIAGE
EKA497/EKA19	BEARING BRACKET FOR CUTTER CARRIAGE
EKA497/EKA20	END COVER FOR BEARING BRACKET
EKA497/EKA37	TOP SPINDLE CUTTERHEAD
EKA497/EKA38	TOP SPINDLE CUTTERHEAD
EKA497/EKA39	BOTTOM SPINDLE CUTTERHEAD
EKA497/EKA40	BOTTOM SPINDLE CUTTERHEAD
EKA497/EKA47	BRAKE BOX
EKA497/EKA48	END CAP FOR BRAKE BOX
EKA497/EKA49	BRAKE DRUM
EKA497/EKA55	ADJUSTING SCREW FOR CARRIAGES
EKA497/EKA56	SCREW FOR VEE STRIP
EKA497/EKA69	FEATHER FOR CUTTER SPINDLE
EKA497/EKA70	FEATHER FOR CUTTER SPINDLE
EKA497/EKA79	RAISING SCREW FOR TOP CARRIAGE
EKA497/EKA80	COLLAR FOR RAISING SCREW
EKA497/EKA90	DISTANCE SLEEVE FOR SPINDLE
EKA497/EKA95	SPECIAL HEX HEAD SCREWS FOR HOLDING DOWN MAIN FRAME
EKA497/EKA96/A	TOP CUTTER SPINDLE
EKA497/EKA97/A	BOTTOM CUTTER SPINDLE
EKA497/EKA98	KEY FOR BRAKE DRUM
EKA497/EKA99	ADJUSTING SCREW
EKA497/EKA118	CUTTER FOR BOTTOM BLOCK
EKA497/EKA145	SPRING FOR STOP STRIP
EKA497/EKA180	TOP SCRIBING CUTTER SPINDLE
EKA497/EKA184	DISTANCE SLEEVE

EKA497/EK 134	CROSS BAR FOR CLAMP
EKA497/EK 135	BOLT FOR CLAMP
EKA497/EK 136	SCREW FOR TABLE ROLLERS
EKA497/EK137	TABLE STOP
EKA497/EK138	PIN FOR STOP
EKA497/EK143	SLEEVE FOR STOP
EKA497/EK146	WEAR PAD FOR CLAMP SPINDLE
EKA497/EK150	CUTTERS FOR TOP HEAD
EKA497/EK151	CUTTERS FOR BOTTOM HEAD
EKA497/EK155	SPUR CUTTERS
EKA497/EK161	NUT FOR CRAMP SPINDLE
EKA497/EK162	SPLIT RING
EKA497/EK164	LIP PLATE FOR FRONT TABLE
EKA497/EK165	DUST PLATE FOR FRONT TABLE
EKA497/EK171	GRUBSCREWS FOR FRONT TABLE
EKA497/EK173	PIN FOR SLEEVE FOR STOP
EKA497/EK174	LOCKNUTS FOR SLEEVE FOR STOP
EKA497/EK197	PAD FOR LOCKING SCRIBING SPINDLE
EKA497/EK206/A	BEARING NUT FOR SCRIBING APPARATUS
EKA497/EK233	NUT FOR INTERMEDIATE SLIDE FOR SCRIBING SPINDLE
EKA497/1A	SAW COLLAR
EKA497/1A	TWO BALL HANDLE
EKA497/1B	BALL BEARING LOCKNUT
EKA497/1B	SAW COLLAR
EKA497/2	GREASE RETAINER
EKA497/2A	HANDWHEEL
EKA497/2A	DRIVING PEG
EKA497/2B	BALL BEARING LOCKNUT
EKA497/3	COLLAR
EKA497/3A	BALL BEARING LOCKNUT

EKA497/EKA488	VEE STIP FOR SCRIBERS
EKA497/EKA489	HORIZONTAL ADJ. SCREW BOTTOM SCRIBER
EKA497/EKA490	VERTICAL ADJ. SCREW TOP SCRIBER
EKA497/EKA491	VERTICAL ADJ. SCREW BOTTOM SCRIBER
EKA497/EK7	NUT FOR TOP CUTTER CARRIAGE
EKA497/EK12	BEARING FOR TOP RAISING SCREW
EKA497/EK57	FRONT TABLE
EKA497/EK58	SLIDING TABLE
EKA497/EK59	FENCE
EKA497/EK60	END COVER FOR TABLE ROLLERS
EKA497/EK61	STOP
EKA497/EK62	BEARING NUT FOR CLAMP SCREW
EKA497/EK63	CLAMP BODY
EKA497/EK64	CLAMP HANDLE
EKA497/EK65	STOP FOR FENCE
EKA497/EK70	BACK TABLE
EKA497/EK102	KEY FOR CUTTER SPINDLES
EKA497/EK104	ADJUSTING SCREW FOR TOP CUTTER CARRIAGE SLIDE
EKA497/EK106	PIVOT PIN FOR GUARDS
EKA497/EK117	SPINDLE FOR TABLE ROLLERS
EKA497/EK118	LOCKING SLEEVE FOR SPINDLE FOR TABLE ROLLERS
EKA497/EK120	STOP ROD
EKA497/EK121	STOP STRIP FOR SLIDING TABLE
EKA497/EK122	STUD FOR STOP STRIP
EKA497/EK123	FLAT SCRAPER FOR TABLE WAY
EKA497/EK124	PIVOT PIN FOR FENCE
EKA497/EK126	PLAIN TABLE ROLLER
EKA497/EK128	STAY ROD FOR TABLE WAYS
EKA497/EK130	CLAMP SPINDLE
EKA497/EK131	PIVOT PIN FOR CLAMP
EKA497/EK133	CLAMP POST

EKA497/3D	STAR HANDWHEEL
EKA497/4B	HANDWHEEL
EKA497/5	COLLAR
EKA497/7A	BALL BEARING LOCKNUT
EKA497/7B	BALL BEARING LOCKNUT
EKA497/11/A	HANDWHEEL
EKA497/17	GREASE RETAINER
EKA497/102	GREASE RETAINER

EKA497/CR4	END CAP FOR TAIL END
EKA497/EV27	NUT FOR RAISING SCREW
EKA497/GM210	FELT WIPERS
EKA497/ME116	PAD FOR CHIPBREAKER ROD
EKA497/ME117	WASHER FOR SPRING BALANCE
EKA497/RD43	PIVOT PIN
EKA497/SKF0.8	BEARING
EKA497/SKF2209	BEARING
EKA497/SKF2309	BEARING
EKA497/SKF RL10	BEARING
EKA497/SKF RM8	BEARING
EKA497/SKF RM10	BEARING
EKA497/SKF RM12	BEARING
EKA497/SSR4	BRASS SCALE $3\frac{1}{4}'' \times \frac{5}{8}'' \times 20$ B.W.G.
EKA497/SSR40	BRASS SCALE $3\frac{1}{4}'' \times \frac{5}{8}'' \times 20$ B.W.G.
EKA497/WA497	NUT FOR SCRIBER SPINDLE
EKA497/WA498	NUT FOR SCRIBER SPINDLE

EKA497/WF1407	NUT FOR SCRIBER SPINDLE
---------------	-------------------------

EKA497/YK91	BRAKE LINING
-------------	--------------

EKA497/ZE6	TERMINAL BOX
EKA497/ZE7	TERMINAL BOX COVER

EKA497/EKA366	KEY FOR TOP SCRIBER SPINDLE
EKA497/EKA367	KEY FOR SAW SPINDLE
EKA497/EKA418	BOTTOM SCRIBING SPINDLE
EKA497/EKA421	BALL BEARING LOCKNUT FOR SPINDLE
EKA497/EKA431	BASEPLATE
EKA497/EKA432	MAIN FRAME
EKA497/EKA433	RIGHT HAND SLIDEWAY
EKA497/EKA434	LEFT HAND SLIDEWAY
EKA497/EKA435	BOTTOM TENON CUTTER CARRIAGE
EKA497/EKA436	TOP TENON CUTTER CARRIAGE
EKA497/EKA437	TOP TENON SLIDE
EKA497/EKA438	BOTTOM TENON SLIDE
EKA497/EKA439	TOP SCRIBER SLIDE
EKA497/EKA440	BOTTOM SCRIBER SLIDE
EKA497/EKA441	RAISING NUT FOR TOP TENON
EKA497/EKA442	BRACKET FOR TENON SCREW
EKA497/EKA443	BRACKET FOR BOTTOM TENON NUT
EKA497/EKA444	NUT FOR BOTTOM TENON
EKA497/EKA445	BRACKET FOR TOP TENON
EKA497/EKA446	SLIDE FOR SCRIBER
EKA497/EKA447	SLIDE FOR BOTTOM SCRIBER
EKA497/EKA448	BEARING FOR BOTTOM RAISING SCREW
EKA497/EKA451	LOWER SAW GUARD FOR CUT OFF SAW
EKA497/EKA475	VEE STRIP FOR SCRIBERS
EKA497/EKA476	VEE STRIP FOR TENON SLIDES
EKA497/EKA477	LIP PLATE FOR VERTICAL SLIDES
EKA497/EKA479	WEAR STRIP
EKA497/EKA480	CLAMP PLATE FOR VERTICAL SLIDES
EKA497/EKA481	POINTER (BOTTOM TENON)
EKA497/EKA482	POINTER FOR TOP TENON
EKA497/EKA483	STRIP FOR BOTTOM CARRIAGE BRACKET

EKA497/EKA185	END COVER
EKA497/EKA186	LOCKNUT
EKA497/EKA187	END COVER
EKA497/EKA188	GUARD FOR BOTTOM C/BLOCK
EKA497/EKA206	HANDWHEEL FOR TOP HORIZONTAL SCRIBER SHAFT
EKA497/EKA208	RAISING SCREW FOR BOTTOM CUTTER CARRIAGE
EKA497/EKA211	CLAMP PLATE
EKA497/EKA212	RUBBER PAD FOR CLAMP
EKA497/EKA216	GUARD FOR TOP CUTTERBLOCK
EKA497/EKA233	HEX COLLAR FOR BOTTOM SCRIBER
EKA497/EKA234	HANDWHEEL SHAFT FOR BOTTOM SCRIBER
EKA497/EKA235	PIN FOR BOTTOM SCRIBER
EKA497/EKA252	NUT FOR SAW SPINDLE
EKA497/EKA254	STUD FOR OPERATING BRAKE
EKA497/EKA256	STOP PIN FOR TOP SCRIBER
EKA497/EKA273	STATOR FRAME FOR CUT OFF SAW
EKA497/EKA274	STATOR FRAME HOUSING FOR CUT OFF SAW
EKA497/EKA275	TOP SAW GUARD FOR CUT OFF SAW
EKA497/EKA278	BEARING HOUSING FOR CUT OFF SAW
EKA497/EKA279	END COVER FOR CUT OFF SAW
EKA497/EKA280	STATOR FRAME NUT FOR CUT OFF SAW
EKA497/EKA281	CUT OFF SAW SPINDLE
EKA497/EKA282	LOCKING STUD FOR CUT OFF SAW
EKA497/EKA283	LOCKING PAD FOR CUT OFF SAW
EKA497/EKA284	STATOR FRAME KEY
EKA497/EKA285	ADJUSTING SCREW FOR CUT OFF SAW
EKA497/EKA286	BEARING END COVER
EKA497/EKA336	CLAMP SPRING
EKA497/EKA337	PUSH BUTTON PLATE
EKA497/EKA355	PLATE FOR SAW GUARD
EKA497/EKA364	BUSH FOR TOMMY BAR
EKA497/EKA365	PIVOT PIN FOR GUARD (TOP TENON)

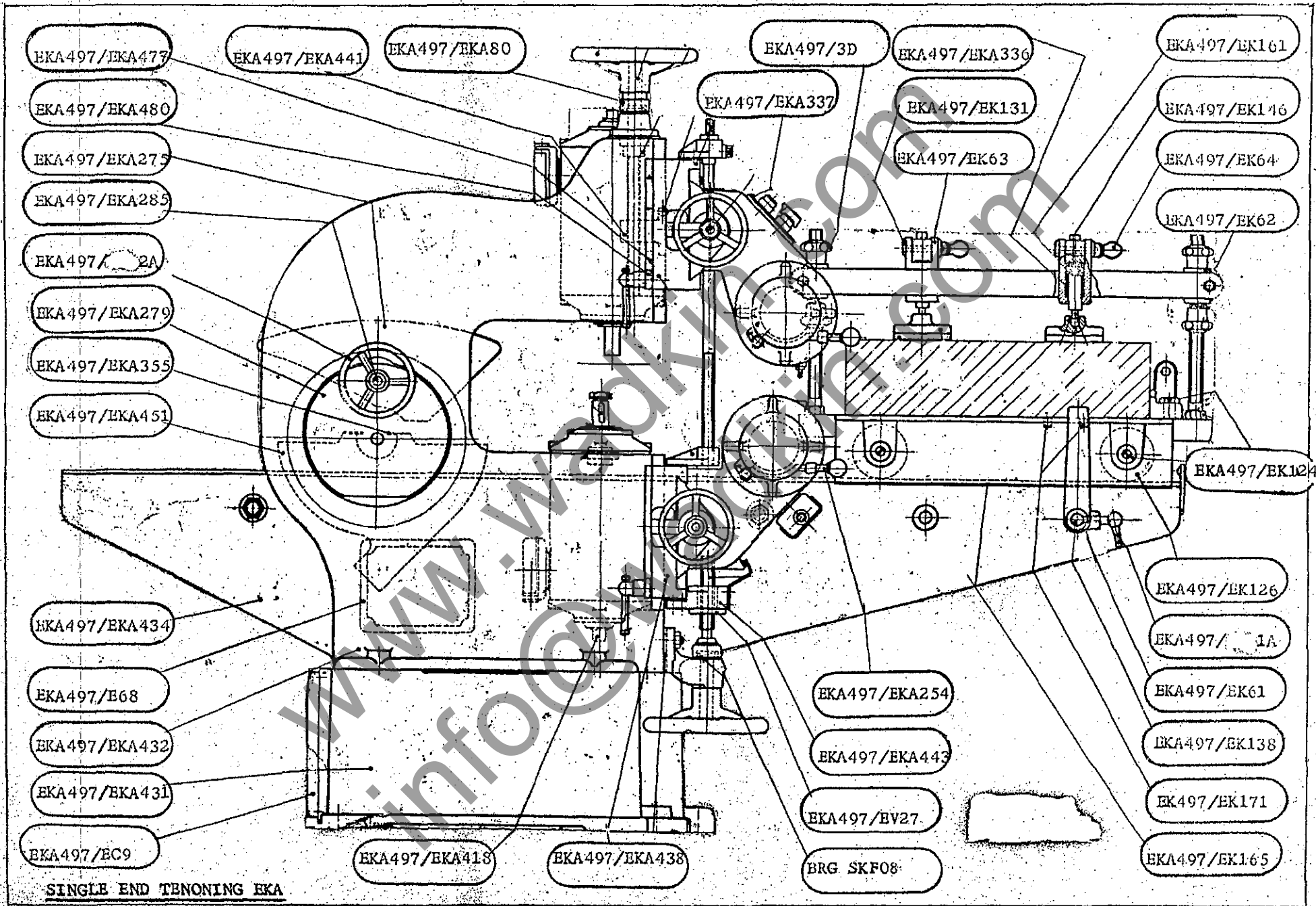

SINGLE END TENONING EKA

